

EMC Fibre Channel with QLogic Host Bus Adapters in the Windows Environment

**P/N 300-001-164
REV A07**

EMC Corporation
Corporate Headquarters:
Hopkinton, MA 01748 -9103
1-508 -435 -1000
www.emc.com

Copyright © 2001–2005 EMC Corporation. All rights reserved.

Updated March 2005

EMC believes the information in this publication is accurate as of its publication date. The information is subject to change without notice.

THE INFORMATION IN THIS PUBLICATION IS PROVIDED "AS IS." EMC CORPORATION MAKES NO REPRESENTATIONS OR WARRANTIES OF ANY KIND WITH RESPECT TO THE INFORMATION IN THIS PUBLICATION, AND SPECIFICALLY DISCLAIMS IMPLIED WARRANTIES OF MERCHANTABILITY OR FITNESS FOR A PARTICULAR PURPOSE.

Use, copying, and distribution of any EMC software described in this publication requires an applicable software license.

Trademark Information

EMC², EMC, ApplicationXtender, Celerra, CentraStar, CLARiiON, CLARAlert, Connectrix, Dantz, Direct Matrix Architecture, DiskXtender, Documentum, EmailXtender, EmailXtract, HighRoad, Legato, Navisphere, RepliStor, PowerPath, ResourcePak, Retrospect, Smarts, SnapView/IP, SRDF, Symmetrix, TimeFinder, VisualSAN, and where information lives are registered trademarks and EMC ControlCenter, EMC Developers Program, EMC OnCourse, EMC Proven, EMC Snap, EMC Storage Administrator, Access Logix, ArchiveXtender, Automated Resource Manager, AutoSwap, AVALONidm, C-Clip, Celerra Replicator, Centera, CLARevent, CopyCross, CopyPoint, DatabaseXtender, Direct Matrix, DiskXtender 2000, EDM, E-Lab, EmailXaminer, Engenuity, eRoom, FarPoint, FLARE, InfoMover, MirrorView, NetWin, NetWorker, OnAlert, OpenScale, Powerlink, RepliCare, SafeLine, SAN Advisor, SAN Copy, SAN Manager, SDMS, SnapSure, SnapView, StorageScope, SupportMate, SymmAPI, SymmEnabler, Symmetrix DMX, and VisualSRM are trademarks of EMC Corporation. All other trademarks used herein are the property of their respective owners.

Preface	vii
Chapter 1 Introduction	
Understanding Persistent Binding in a Fabric Environment	1-2
Chapter 2 Installing and Configuring the HBA Driver	
Introduction	2-2
Downloading QLogic Drivers and Firmware	2-2
Verifying and Downloading the Documentation	2-2
Installing an HBA	2-3
Special Installation Sequence for Stratus ftServers and EMC CLARiiON Arrays	2-4
Special Instructions for CLARiiON CX200-Series Direct-Connect Dual-Host Clustering Configurations	2-4
EMC HBA Settings	2-8
Pre-Configured Settings.....	2-8
Configuring NVRAM for Stratus ftServers	2-9
Fibre-Down Servers with Embedded QLogic HBAs.....	2-10
Updating Firmware/BIOS and Applying NVRAM Settings	2-10
Manually Setting the HBA Data Rate	2-12
Setting the Topology for QLA22xx/23xx and Windows ..	2-13
Installing the HBA Driver.....	2-14
Driver Revision History.....	2-14
Where to Find the Driver.....	2-14
Windows 2003 STORPort Updates	2-15
Extended Error Logging by QLogic Drivers	2-15
Installation Procedure for Windows NT Hosts.....	2-15

Installation Procedure for Windows 2000 and Windows 2003 Hosts.....	2-16
Updating the HBA Driver in a Windows 2000 or Windows 2003 Host.....	2-18
Upgrading to Windows 2003 from Windows 2000 or Windows NT 4.0	2-20
Replacing an HBA	2-21
Procedure for Replacing a QLogic HBA in Stratus ftServers without Rebooting	2-21

Chapter 3 Configuring an EMC Boot Device

Introduction.....	3-2
Boot-from-SAN Configuration Restrictions	3-2
Risks of Booting from the Storage Array	3-2
How to Determine I/O Latency and Load on the Boot LUN	3-3
Boot Crashdump Save to Disk Behavior.....	3-4
Boot-from-SAN with MSCS	3-4
Configuring a Symmetrix Boot Device.....	3-5
Configuring the Boot BIOS	3-5
Installing the Windows OS onto the Boot Device.....	3-7
Installing EFI boot code onto the HBA.....	3-8
Configuring QLogic EFI boot code to boot from an External Array.....	3-10
Procedure to Install Windows Server 2003 on a Fibre Channel Disk (Only for system with floppy disk drive) ..	3-13
Configuring a CLARiiON Boot Device	3-14
Procedure Flowchart	3-14
Requirements	3-16
Preparing the Storage System.....	3-17
Setting Up the HBA BIOS.....	3-18
Preparing the Fabric.....	3-19
Preparing the Server	3-22
Configuring the HBA Boot BIOS.....	3-23
Installing Windows	3-25
Verifying HBA Driver and Digital Signature Installation	3-28
Assigning a Permanent Boot Drive Letter for Windows NT	3-29
Installing Multipath and Failover Software	3-29
Installing Additional Navisphere Host Agent Software ..	3-30
Configuring Additional Boot Port Name Entries in the Boot BIOS.....	3-31

	Starting a Fresh Installation.....	3-34
	Boot Time and LUN Availability	3-35
	Replacing a Boot HBA	3-36
	EMC Symmetrix	3-36
	EMC CLARiiON.....	3-36
	How a Server Responds to Failure in the Boot LUN Path	3-37
	Known Issues.....	3-38
Chapter 4	Installing and Configuring the QLogic QLA4010 iSCSI HBA (TOE)	
	Installing the HBA Driver.....	4-2
	Windows 2003 STORPort Updates	4-2
	Installation Procedure for Windows 2000 and Windows 2003 Hosts	4-2
	Updating the HBA Driver in a Windows 2000 or Windows 2003 Host	4-4
	Using the QLogic iSCSI SANSurfer Application to Configure iSCSI Devices	4-6
	Configuring iSNS settings for QLA4010.....	4-8
	Installing and Configuring the QLA4010 iSCSI HBA to boot from an EMC Storage Array	4-14
	Installing Boot BIOS on the QLA4010 iSCSI HBA from DOS	4-14
	Setting Up the HBA BIOS	4-14
	Installing the Windows OS onto the Boot Device	4-16
Appendix A	Third-Party Software	
	QLogic SANSurfer SANBlade Manager	A-2
	SANSurfer Version History	A-3
	VERITAS Volume Manager 3.x for Windows 2000	A-4
	VERITAS Volume Manager 3.0.....	A-4
	VERITAS Volume Manager 3.1 and VERITAS DMP	A-5
	VERITAS Foundation Suite 4.1	A-5
	VERITAS Foundation Suite 4.2.....	A-5
Appendix B	Troubleshooting	
	Problems and Solutions	B-2
	Problem 1.....	B-2
	Problem 2.....	B-2
	Problem 3.....	B-2
	Problem 4.....	B-3

Problem 5.....	B-3
Problem 6.....	B-3
Problem 7.....	B-4
Problem 8.....	B-4
Index.....	i-1

Conventions Used in This Guide

EMC uses the following conventions for notes, cautions, and warnings.

A note presents information that is important, but not hazard-related.



CAUTION

A caution contains information essential to avoid data loss or damage to the system or equipment. The caution may apply to hardware or software.



WARNING

A warning contains information essential to avoid a hazard that can cause severe personal injury, death, or substantial property damage if you ignore the warning.

Typographical Conventions

EMC uses the following type style conventions in this guide:

AVANT GARDE	Keystrokes
Palatino, bold	<ul style="list-style-type: none"> ◆ Dialog box, button, icon, and menu items in text ◆ Selections you can make from the user interface, including buttons, icons, options, and field names
<i>Palatino, italic</i>	<ul style="list-style-type: none"> ◆ New terms or unique word usage in text ◆ Command line arguments when used in text ◆ Book titles
<i>Courier, italic</i>	Arguments used in examples of command line syntax.
Courier	<p>System prompts and displays and specific filenames or complete paths. For example:</p> <pre>working root directory [/user/emc]: c:\Program Files\EMC\Symapi\db</pre>
<i>Courier, bold</i>	<ul style="list-style-type: none"> ◆ User entry. For example: sympoll -p ◆ Options in command line syntax

Related Documentation

- ◆ *EMC Host Connectivity Guide for Windows 2000 and Windows NT*, P/N 300-000-603
- ◆ *EMC Navisphere Manager 5.X Administrator's Guide*, P/N 069001143
- ◆ *EMC Navisphere Manager 6.X Administrator's Guide*, P/N 069001125
- ◆ *EMC ControlCenter Navisphere Host Agent and CLI for Windows 2000 and NT Version 6.X Installation Guide*, P/N 069001151
- ◆ *EMC Navisphere Application Transparent Failover (ATF) for Windows 2000 and NT Administrator's Guide*, P/N 069001164
- ◆ *Storage-System Host Utilities for Windows 2000 and NT Administrator's Guide*, P/N 069001141
- ◆ *PowerPath Installation And Administration Guide for Windows*, P/N 300-000-512

Introduction

This document describes the procedures for installing an EMC-approved QLogic host bus adapter (HBA) into a Windows NT, Windows 2000, or Windows 2003 host environment and configuring the Windows host for connection to an EMC storage array over Fibre Channel.

Review the *EMC Support Matrix* for the latest information on approved HBAs and drivers.

- ◆ Understanding Persistent Binding in a Fabric Environment1-2

Understanding Persistent Binding in a Fabric Environment

Persistent binding is the mechanism to create a continuous logical route from a storage device object in the Windows host to a volume in the EMC® storage array across the fabric.

Without a persistent binding mechanism, the host cannot maintain persistent logical routing of the communication from a storage device object across the fabric to an EMC storage array volume. If the physical configuration of the switch is changed (for example, the cable is swapped or the host is rebooted), the logical route becomes inconsistent, causing possible data corruption if the user application is modifying data through inconsistent logical routing of the communication from the driver entry point to a volume in an EMC storage array across the fabric.

The Windows NT/Windows 2000/Windows 2003 operating system (OS) does not provide a satisfactory means to allow persistent binding. Most software applications access storage using file systems that are managed by the Windows OS. (File systems are represented by drive letters: **C:**, **D:**, and so forth.) For storage devices containing file systems, Windows NT/Windows 2000 writes a disk signature to the disk device. The OS can then identify and associate with a particular drive letter and file system.

Because the disk signature resides on the disk device, changes can occur on the storage end (a cable swap, for example) that can cause a disk device to be visible to the host server in a new location. However, the OS looks for the disk signature and, providing that nothing on the disk changed, associates the signature with the correct drive letter and file system. This mechanism is strictly an OS feature and is not influenced by the Fibre Channel device driver.

Some software applications, however, do not use the Windows file systems or drive letters for their storage requirements. Instead they access storage drives directly, using their own built-in “file systems.” Devices that are accessed in this way are referred to as *raw devices* and are known as *physical drives* in Windows terminology.

The naming convention for physical drives is simple and is always the same for software applications using them. A raw device under Windows NT/Windows 2000/Windows 2003 is accessed by the name `\\PHYSICALDRIVEXXX`, where **XXX** is the drive number. For example, a system with three hard disks attached using a QLogic Fibre Channel controller assigns the disks the names

\\PHYSICALDRIVE0, \\PHYSICALDRIVE1, and \\PHYSICALDRIVE2. The number is assigned during the disk discovery part of the Windows boot process.

During boot-up, the Windows OS loads the driver for the storage HBAs. After loaded, the OS performs a SCSI **Inquiry** command to get information about all of the attached storage devices. Each disk drive that it discovers is assigned a number in a *semi-biased* first come, first serve fashion based on HBA. (*Semi-biased* means that the Windows system always begins with the controller in the lowest-numbered PCI slot where a storage controller resides. After the driver for the storage controller is loaded, the OS selects the adapter in the lowest-numbered PCI slot to begin the drive discovery process.)

It is this naming convention and the process by which drives are discovered that makes persistent binding (by definition) impossible for Windows NT/Windows 2000/Windows 2003. Persistent binding requires a continuous logical route from a storage device object in the Windows host to a volume in an EMC storage array across the fabric. As mentioned above, each disk drive is assigned a number in a first come, first serve basis. This is where faults can occur.

Example Imagine this scenario—A host system contains controllers in slots 0, 1, and 2. Someone removes a cable from the QLogic controller in host PCI slot 0, then reboots the host.

During reboot, the Windows OS loads the QLogic driver during reboot and begins disk discovery. Under the scenario presented above, there are no devices discovered on controller 0, so the OS moves to the controller in slot 1 and begins naming the disks it finds, starting with \\PHYSICALDRIVE0. Any software applications that were accessing \\PHYSICALDRIVE0 before the reboot will be unable to locate their data on the device, because it has changed.

The following figure shows the original configuration before the reboot. HBA0 is in PCI slot 0 of the Windows host. Each HBA has four disk devices connected to it, so Windows has assigned the name \\PHYSICALDRIVE0 to the first disk on HBA0. Each disk after that is assigned a number in sequence as shown in the figure.

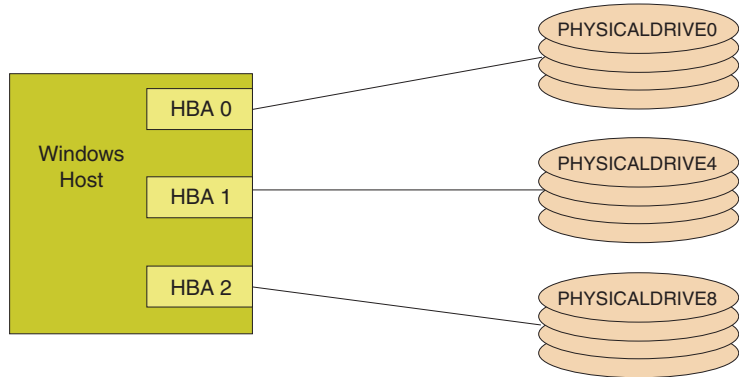

The next figure shows the same host after the cable attached to HBA0 has been removed and the host rebooted. Because Windows was not able to do a discovery on HBA0, it assigned **\\PHYSICALDRIVE0** to the first device it discovered. In this case, that first device is connected to HBA1. Due to the shift, any software application accessing **\\PHYSICALDRIVE0** will not find data previously written on the original **\\PHYSICALDRIVE0**.

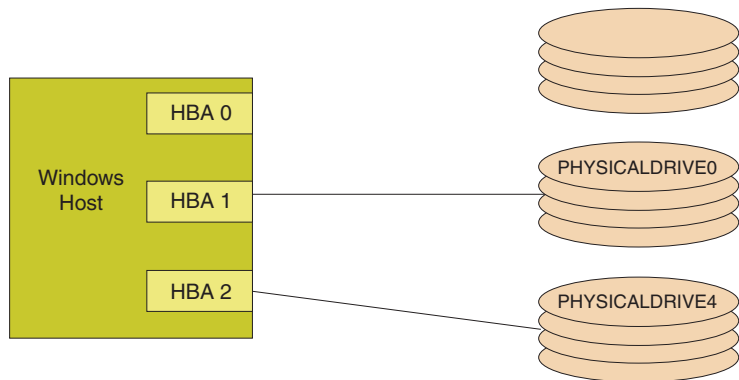

The default driver behavior does not store target bindings between host reboots. The bindings are dynamically generated by the HBA when new target devices are detected.

Tape devices are treated the same as disk devices in Windows with respect to persistent binding. Refer to your tape device documentation for more information.

Installing and Configuring the HBA Driver

This chapter describes the procedures for installing an EMC-approved QLogic host bus adapter (HBA) into a Windows NT, Windows 2000, or Windows 2003 host environment and configuring the Windows host for connection to an EMC storage array over Fibre Channel.

- ◆ Introduction 2-2
- ◆ Installing an HBA..... 2-3
- ◆ EMC HBA Settings..... 2-8
- ◆ Installing the HBA Driver 2-14
- ◆ Updating the HBA Driver in a Windows 2000 or Windows 2003 Host 2-18
- ◆ Upgrading to Windows 2003 from Windows 2000 or Windows NT 4.0..... 2-20
- ◆ Replacing an HBA..... 2-21

Introduction

The procedure described here was written specifically for the QLA22xx and QLA23xx families of Fibre Channel HBAs; however, the procedures for installing the adapter BIOS and Windows drivers are identical for QLA21xx, QLA22xx, and QLA23xx.

When installing or upgrading the BIOS and drivers, be sure to use the latest versions supported by EMC. Review the *EMC Support Matrix* for the latest information on approved HBAs and drivers.

Also refer to the *EMC Host Connectivity Guide for Windows 2000 and Windows NT*, available on Powerlink, for related information.

Downloading QLogic Drivers and Firmware

If you need to download the latest HBA driver or firmware:

1. Access www.qlogic.com.
2. Click **Downloads** at the left side of the screen.
3. Click the **EMC** link to the right of **OEM-approved Drivers/Firmware**.
4. Find the description of your HBA driver in the **Name** column of the table for your HBA model. Then click the **Download** link in the associated **Download** column.

Verifying and Downloading the Documentation

To check for the latest revision of this document (and download it if necessary):

1. Access www.qlogic.com.
2. Click **Downloads** at the left side of the screen.
3. Click the **EMC** link to the right of **OEM-approved Drivers/Firmware**.
4. Find the description of your HBA driver in the **Name** column of the table for your HBA model. Then click the **Readme** link in the associated **Description** column.

Installing an HBA

Follow the instructions included with your HBA. The HBA installs into a single slot, and has no user-configurable jumpers or switches.

Follow these steps to connect the cable to the HBA:

1. (Optical cable only) Remove the protective covers on each fiber-optic cable.
2. Plug one end of the cable into the connector on the HBA as shown in the appropriate figure. (The hardware might be rotated 90 degrees clockwise from the orientation shown.)

- Copper Cable:

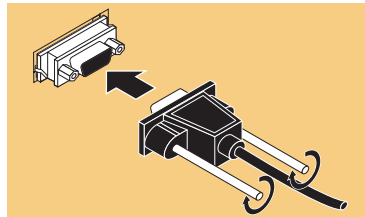

- LC Optical Cable:

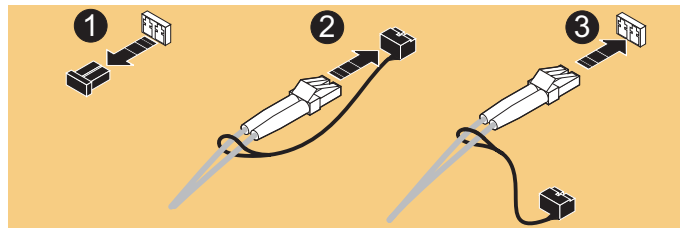

- SC Optical Cable:

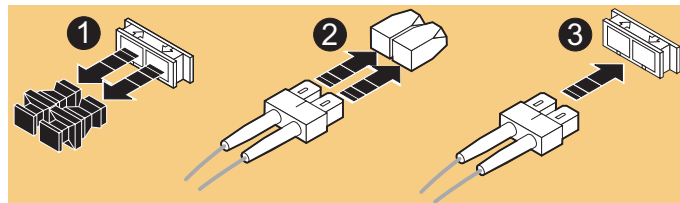

3. Plug the other end of the cable into a connector on the storage system or a hub/switch port.

4. Label each cable to identify the HBA and the storage/switch/hub port to which it connects.
5. After connecting all HBAs in the server, power up the server.

Special Installation Sequence for Stratus ftServers and EMC CLARiiON Arrays

A specific installation sequence is required when installing QLogic HBAs with the Stratus ftServers and EMC CLARiiON® storage. Failure to follow this sequence may result in a STOP: 0X0000007B bugcheck error when booting the Stratus server for the first time when connected to EMC CLARiiON storage.

With the Stratus ftServer, if the HBA detects EMC CLARiiON array targets but no accessible LUNs, it prevents the Stratus server from booting. In this configuration, the Stratus ftServer attempts to boot from the array, instead of booting from the internal boot drive.

To avoid this issue before storage is correctly assigned, either boot the Stratus ftServer before connecting the fibre cables to the HBAs or, if connected to a fabric, disable the HBA ports on the switch before booting the ftServer.

After the system has booted, connect the cables or reenble the switch ports. Verify that the HBAs are logged in to the EMC CLARiiON array; then stop and restart the Navisphere agent on the ftServer host. This will register the HBAs with the CLARiiON array and allow the HBA to properly detect the available LUNs.

Special Instructions for CLARiiON CX200-Series Direct-Connect Dual-Host Clustering Configurations

For CLARiiON CX200-Series direct-connect dual-host cluster configurations only with QLA234x HBAs, you must follow all procedures described in this section.

Check for an Updated HBA Driver

For CLARiiON CX200-Series direct-connect dual-host cluster configurations with only QLA234x HBAs, you may need a separate driver and firmware download. The *EMC Support Matrix* notes whether separate driver and firmware files are required.

For each HBA that is determined to require updated firmware and drivers, follow the instructions under *Downloading QLogic Drivers and Firmware* on page 2-2. Be sure to reference the Name and Description

fields to select the correct CX200-Series direct-connect dual-host cluster-compatible files.

Reconfigure the HBA Jumper

For CLARiON CX200-Series direct-connect dual-host cluster configurations with only QLA234x HBAs, you must change the default HBA optic jumper position:



CAUTION

Modifying the jumper setting without using the recommended firmware/drivers can cause the HBA to lose connectivity.

1. Remove the HBA from the server as instructed by your server guide.
2. Locate jumper(s) J3 (QLA2340) or J3 and J4 (QLA2342), shown in the following figure:

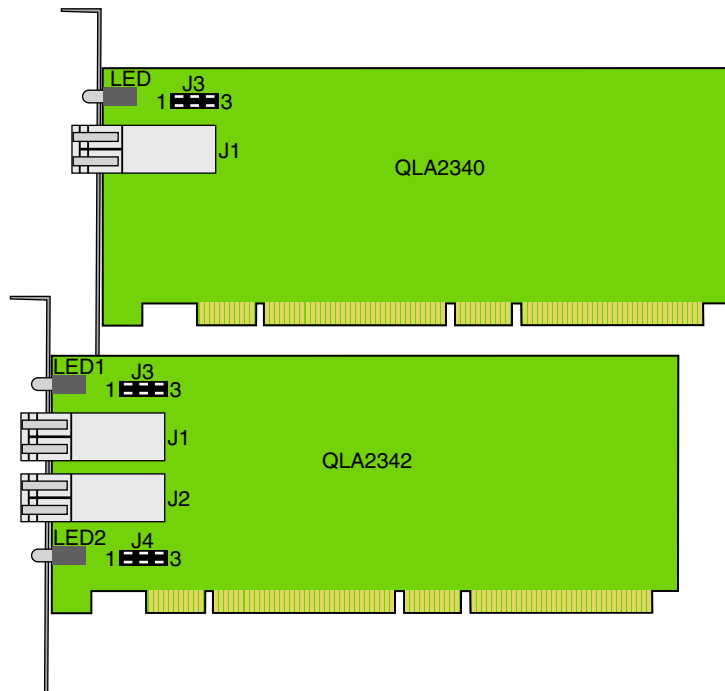

3. Move the jumper(s), onto pins 1–2 (if not already there).

Set the HBA FC-AL Loop ID

If later you wish to return the jumper(s) to the default factory position, repeat step 2, returning the jumper to pins 2-3.

While configuring a QLA234x HBA for Windows NT or Windows 2000 and connection to EMC CLARiiON CX200-Series for direct-connect cluster configurations, you must manually set the HBA FC-AL Loop ID. Follow these steps to enable loop hard addressing and set the loop ID on each HBA:

Perform this procedure on all nodes in the cluster connected to the CX200-Series array.

1. Boot the Windows host; press CTRL-Q when prompted to Press <CTRL-Q> for Fast!UTIL. (This prompt appears with the QLogic startup banner.)
2. After the Fast!UTIL program loads, the initial display depends on whether there are multiple QLogic HBAs installed in the server:
 - If there is only one QLogic HBA, the Fast!UTIL **Options** menu appears.
 - If there are multiple QLogic HBAs, a list of memory addresses occupied by those HBAs appears.
Using the arrow keys, select the desired HBA and press ENTER. The Fast!UTIL **Options** menu appears.
3. Select **Configuration Settings** from the Fast!UTIL **Options** menu, and press ENTER.
4. Select **Host Adapter Settings** from the **Configuration Settings** menu.
5. Select **Adapter Hard Loop ID** from the **Host Adapter Settings** menu and press ENTER until the value is **Enabled**.
6. Select **Hard Loop ID** and press ENTER.

The loop ID value entered here is the decimal representation of the FC-AL loop ID. You do not need to perform any FC-AL AL_PA hexadecimal translation.

HBAs connected to the same SP should all have unique hard loop IDs. Select 0 for all HBAs on one node, select 1 for all HBAs on the next node, and so on.

7. Enter a value for the loop ID and press ENTER.
8. Press ESC to return to the **Configuration Settings** menu.
9. Press ESC to return to the Fast!UTIL **Options** menu.
10. When prompted to save changes made to the current adapter, select **Save Changes** and press ENTER.
11. If there are more adapters to configure, choose **Select Host Adapter**, and repeat steps 3 through 11 for each adapter.
12. Press ESC to exit Fast!UTIL.
13. Reboot the host.
14. Repeat this procedure on all nodes in the cluster connected to the CX200-Series array.
15. While you are in the BIOS, you can verify that the topology is set correctly for direct connect (FC-AL). Follow the instructions under *Setting the Topology for QLA22xx/23xx and Windows* on page 2-13.



CAUTION

Future use of the firmware NVRAM file to apply settings will overwrite and possibly invalidate the changes made above. If you will later update using a firmware NVRAM file, be sure it is listed and supports this CX200-Series direct-connect cluster configuration.

To restore EMC default HBA settings, either reload the approved EMC NVRAM file, or return to step 5 and ensure that **Adapter Hard Loop ID** is set to **Disabled**.

EMC HBA Settings

EMC requires configuring the QLogic BIOS settings with the EMC-approved NVRAM settings file. This file contains all of the BIOS settings for the QLogic adapters that have been tested and approved for connection to the EMC storage array.

The QLogic CD-ROM contains the latest EMC-approved BIOS and NVRAM settings files at the time of creation of the CD-ROM. If more recent files exist, you can find them on the QLogic website. Refer to *Downloading QLogic Drivers and Firmware* on page 2-2.

Pre-Configured Settings

The following parameters are preconfigured in the EMC-approved NVRAM settings file. They are also configurable in the **Host Adapter Settings** menus.

These menus and selections, when viewed in SANSurfer v2.0.25 and later, may appear under different headings.

These settings apply to PowerPath®/ATF and non-HA connections.

Parameter	QLogic Default Setting	EMC-Approved Setting
Data Rate	0 (1 Gb/s)	2 (Auto Select)
Execution Throttle	16	256
Connection options (topology)	2 (Loop preferred, otherwise point-to-point)	2 (Loop preferred, otherwise point-to-point)
Enable LIP Full Login	Yes	Yes
Enable Target Reset	No	Yes
Port Down Retry Count	8	45
Luns Per Target	8	256
Adapter Hard Loop ID	Enabled	Disabled
Hard Loop ID	125	0
Descending Search LoopID	0	1

Configuring NVRAM for Stratus ftServers

If you have not received QLogic HBAs with the EMC configurations pre-loaded, you may have to perform the following procedure. If your HBAs have been pre-configured, proceed to *Installing the HBA Driver* on page 2-14.

During POST, Stratus ftServers present only one HBA for configuration in a multiple-HBA system. This is the way the ftServer manages HBA failover. In order to successfully configure multiple HBAs, each HBA must be part of an enabled Core PCI chassis at some point. The following procedure explains how this can be done for each chassis.

On Stratus ftServer 5200 systems, the HBA must be in a Core Chassis. Cards in an Expansion Chassis must be moved to a Core Chassis to be available for configuration.

1. To set the first HBA, follow these procedures:
 - *Updating Firmware/BIOS and Applying NVRAM Settings* on page 2-10
 - *Manually Setting the HBA Data Rate* on page 2-12
 - *Setting the Topology for QLA22xx/23xx and Windows* on page 2-13

Ignore any steps that pertain to multiple adapters.

Note the Core PCI Chassis that is powered up while changing the settings. After completing the changes, power down the system and prepare to configure the alternate chassis.

2. Noting the PCI Chassis that was powered up in the previous step:
 - For Stratus ftServer 3200 systems, loosen the Phillips-head screw on the top right of the chassis, effectively removing power from that chassis.
 - For Stratus ftServer 5200 systems, leave the chassis powered down.
3. Power up the system using the alternate PCI Chassis and set the second HBA by following these procedures:
 - *Updating Firmware/BIOS and Applying NVRAM Settings* on page 2-10
 - *Manually Setting the HBA Data Rate* on page 2-12
 - *Setting the Topology for QLA22xx/23xx and Windows* on page 2-13

Ignore any steps that pertain to multiple adapters.

4. Shut down the server.
5. Before powering up the server, restore power to the PCI Chassis:
 - For Stratus ftServer 3200 systems, tighten the Phillips-head screw that you loosened on the top right of the chassis.
 - For Stratus ftServer 5200 systems, power up the chassis.
6. Power up the server and proceed to *Installing the HBA Driver* on page 2-14.

Fibre-Down Servers with Embedded QLogic HBAs

Fibre-Down servers have a vendor-specific firmware utility and package that is posted on the QLogic website, in the EMC section. Be sure to use the firmware utility and package that matches your server model. You can check for updated firmware on the QLogic website. Follow the steps under *Downloading QLogic Drivers and Firmware* on page 2-2.

Updating Firmware/BIOS and Applying NVRAM Settings

You can update the HBA firmware/BIOS and NVRAM settings either from within a running Windows installation or by booting the server to a DOS command prompt and running the procedure described in this section.

Current 64-bit systems can be updated only from within Windows 2003 using the SANSurfer SANBlade Manager. Refer to *QLogic SANSurfer SANBlade Manager* on page A-2 for instructions.

SANSurfer 2.0.25 cannot be used to upgrade to BIOS 1.4x. Until a later SANSurfer is available, you need to use the procedure *Updating Using a DOS Boot Diskette* on page 2-11 to perform this upgrade.



CAUTION

Do not flash embedded HBAs using the HBA utilities noted in this section. (Refer to *Fibre-Down Servers with Embedded QLogic HBAs*).

Updating While Running Windows

To update while running Windows, refer to *QLogic SANSurfer SANBlade Manager* on page A-2.

Stratus ftServers are not supported using the qLogic SANSurfer SANBlade Manager Software or Agents, and should only be updated using the DOS boot diskette. Refer to *Updating Using a DOS Boot Diskette*.

Updating Using a DOS Boot Diskette

To update using a DOS boot diskette, follow these steps:

The QLogic CD-ROM contains the latest EMC-approved BIOS and NVRAM settings files at the time of creation of the CD-ROM. If more recent files exist, you can find them on the QLogic website. Refer to *Downloading QLogic Drivers and Firmware* on page 2-2.

1. Format a 3.5-inch diskette and extract the BIOS and NVRAM files from the archive file (.zip or self-extracting .exe) onto the diskette.
2. Reboot your Windows host system using a DOS diskette.
3. At the A:\> prompt, insert the diskette that contains the QLogic BIOS files (created in step 1).
4. This step depends on what you want to load:



CAUTION

Do not attempt to run this procedure from a command prompt window.

- To load firmware/BIOS and NVRAM settings, type **FLASUTIL.EXE /L /F** and press ENTER:
- To load NVRAM settings only, type **FLASUTIL.EXE /L** (or **QL2XUTIL.EXE /L**) and press ENTER. (Some BIOS archives have **QL2XUTIL.EXE** instead of **FLASUTIL.EXE**; both are run the same.)

Refer to the `readme.txt` file in the firmware package for complete instructions on the use of the `FLASUTIL.EXE` utility

Use the above commands if all NVRAM files are EMC defaults (QLA23XX = `NVRAM23.dat`, QLA2200 = `NVRAM22.dat`) as included in the EMC firmware kits. If you have a non-standard NVRAM

file name, note that some BIOS versions might require the `/N` parameter (which allows an alternate NVRAM filename to be specified) to load the NVRAM file correctly

Example: `FLASUTIL /L /F /N NVRAM2xx.DAT`

where `NVRAM2xx.DAT` is the non-standard NVRAM file name.

5. When the procedure has finished, remove the diskette and reboot the host.

Manually Setting the HBA Data Rate

The HBA driver for a QLA2310 has a data rate setting that lets you specify 1 Gb, 2 Gb, or Auto Select mode. (The EMC default setting is Auto Select mode.)

For any device connected to the HBA, set the device data rate (if applicable) before setting the HBA data rate.

Current 64-bit systems can be updated only from within Windows 2003 using the SANSurfer SANBlade Manager. Refer to *QLogic SANSurfer SANBlade Manager* on page A-2 for instructions.

For every HBA on which you want to manually set the HBA data rate, follow these steps.

1. Reboot the system.
2. At startup, watch for the QLogic BIOS screen and when prompted to enter Fast!Util, press CTRL-Q.
3. Select **host adapter**.
4. Select **Configuration Settings**.
5. Select **Extended Firmware Settings**.
6. Press the Down Arrow until you select **Data Rate**; then press ENTER.
7. Select the appropriate speed for the device to which the HBA connects. EMC recommends using the default setting of option 2, Auto Select.
8. Press ESC repeatedly until you reach the `Save Changes` prompt, and save the changes for this adapter.
9. Repeat steps 3 through 8 for each adapter.

Setting the Topology for QLA22xx/23xx and Windows

While using a QLA22xx or QLA23xx HBA for Windows NT, Windows 2000, or Windows 2003, the default EMC configured topology is set for “loop preferred, otherwise point to point.” If you want to change this value, you can manually set the adapter topology.

Follow these steps to set the topology:

Current 64-bit systems can be updated only from within Windows 2003 using the SANSurfer SANBlade Manager. Refer to *QLogic SANSurfer SANBlade Manager* on page A-2 for further instructions.

1. Boot the Windows host and press CTRL-Q when prompted to Press <CTRL-Q> for Fast!UTIL. (This prompt appears with the QLogic startup banner.)
2. After the Fast!UTIL program loads, the initial display will depend on whether there are multiple QLogic HBAs installed in the server:
 - If there is only one QLogic HBA, the Fast!UTIL **Options** menu appears.
 - If there are multiple QLogic HBAs, a list of memory addresses occupied by those HBAs appears. Using the arrow keys, select the desired HBA and press ENTER. The Fast!UTIL **Options** menu appears.
3. Select **Configuration Settings** from the Fast!UTIL **Options** menu and press ENTER.
4. Select **Extended Firmware Settings** from the **Configuration Settings** menu and press ENTER.
5. Select **Connection Options** and press ENTER.
6. Select the topology desired for your configuration.
7. Press ESC to return to the **Configuration Settings** menu.
8. Press ESC to return to the Fast!UTIL **Options** menu.
9. When prompted to save changes made to the current adapter, select **Save Changes** and press ENTER.
10. If there are more adapters to configure, choose **Select Host Adapter** and repeat steps 3 through 9 for each adapter.
11. Press ESC to exit Fast!UTIL.
12. Reboot the host.

Installing the HBA Driver

To use EMC storage array disks with a Windows host, you need an EMC-qualified Fibre Channel HBA driver. The HBA kit includes an EMC-approved driver, which must be installed and configured prior to partitioning the storage array disks. You should also check the QLogic website for the latest EMC-approved version. (Refer to *Downloading QLogic Drivers and Firmware* on page 2-2.)

Driver Revision History

Driver support is as follows:

- ◆ Version 8.1.5.20 — QLA22xx, QLA23xx (no CX200-Series direct-connect dual host cluster), Windows NT, Windows 2000
- ◆ Version 8.1.5.21 — QLA23xx, Windows NT, Windows 2000
- ◆ Version 8.2.1.20 — QLA23xx, Windows 2000
- ◆ Version 8.2.2.20 — QLA23xx STORPort, Windows 2003 only
- ◆ Version 8.2.2.25 — QLA23xx, Windows 2000 and Windows 2003
- ◆ STORPort 8.2.3.26 and SCSIPort 8.2.3.21 — QL23xx, Windows 2003 (SCSI and STOR) and Windows 2000 (SCSI only)
- ◆ STORPort Version 8.2.3.27 — QLA23xx, Windows 2003 only
- ◆ STORPort 9.0.0.17 and SCSIPort 9.0.0.12 — QL23xx, Windows 2003 (SCSI and STOR) and Windows 2000 (SCSI only)
- ◆ STORPort 9.0.1.17 and SCSIPort 9.0.1.12 — QL23xx, Windows 2003 (SCSI and STOR) and Windows 2000 (SCSI only)

Where to Find the Driver

You can find the Fibre Channel HBA driver:

- ◆ on the QLogic CD-ROM that accompanied the HBA. Copy the driver from the OS-specific directory: **\WindowsNT4** or **\Windows2000**.
- ◆ on the QLogic website. Refer to *Downloading QLogic Drivers and Firmware* on page 2-2.

To ease installation of the driver, unzip the driver file onto a blank diskette.

Windows 2003 STORPort Updates

Currently the shipping version of Windows 2003 requires post-RTM hotfixes to resolve some known issues. For all Windows 2003 STORPort installations, you should obtain the current Microsoft QFE hotfix listed in the *EMC Support Matrix* with the HBA driver revisions.

Install this patch before installing the HBA driver.

Extended Error Logging by QLogic Drivers

In driver versions prior to the 9.X family, additional messages were logged in the system event log when the "extended error logging" parameter was enabled in the HBA BIOS. The messages were primarily informational, but often confused users by appearing to be legitimate error messages.

Driver family 9.X and beyond will no longer log these additional messages in the event log even if the "extended error logging" parameter is enabled. New tools have been developed for developers and engineers troubleshooting customer problems without the need for these messages. Visit the website http://www.qlogic.com/support/logs/event_log.asp for information about QLogic event messages."

Installation Procedure for Windows NT Hosts

To install the driver on a Windows NT host, follow these steps:

1. Boot the host with Windows NT 4.0.
2. Open the Control Panel, and double-click the **SCSI Adapter** icon.
3. Select the **Drivers** tab.
4. Click the **Add** button to display the **SCSI Adapter Drivers** database.
5. Select **HAVE DISK**.
6. Locate the disk with the `OEMSETUP.INF` file for the QLogic driver, and click **OK**.

7. Select **QLogic QLA2300 (or QLA2200) PCI Fibre Channel Adapter**, and click **OK** to install it.
8. Reboot the host. It should recognize all new host adapter cards.
9. After rebooting, verify that the driver is installed and has started by checking the **Control Panel, SCSI Adapter, Drivers** window for a statement similar to the following:

```
QLogic QLA2300 PCI-Fibre Channel Adapter (Started)
```

The driver is now loaded, and the adapter is available to the system.

Installation Procedure for Windows 2000 and Windows 2003 Hosts

To install the driver into a Windows 2000 or Windows 2003 host, follow these steps:

1. Boot the host with Windows 2000 or Windows 2003.
2. From the Windows taskbar, select **Start, Programs, Administrative Tools, Computer Management**
3. In the left pane of the **Computer Management** window, click the **Device Manager** icon.
4. If Windows Plug-n-Play does not detect your QLA23xx HBA model, it will be listed as **Unknown** or as a **Fibre Channel Controller** under the **Other Devices** icon in the right pane.

Windows 2000 configurations with Service Pack 1 or higher and Windows 2003 configurations may be able to detect QLA23xx HBAs. If this occurs, the HBA will already be listed under **SCSI Devices**; instead of proceeding with these installation steps, follow the instructions under *Updating the HBA Driver in a Windows 2000 or Windows 2003 Host* on page 2-18.

5. Double-click the first instance of **SCSI Controller** under **Other Devices**.
6. In the next window, click **ReInstall Driver**, then **Next**.
7. Select **Display a list of the known drivers for this device so that I can choose a specific driver**, then click **Next**.
8. Select **SCSI and RAID Controllers**, then click **Next**.
9. Click **Have Disk**.

10. Enter the path to the diskette containing the driver (for example, **A:**), then click **OK**.
11. Select the appropriate QLogic HBA from the list of drivers that appears; then click **Next**.
12. Click **Next** in the next window.
13. Click **YES** to continue the installation.
14. Click **Finish** to complete the driver installation.
15. The system requests that you reboot the system. Select **NO** and click **Close**.
16. The system again requests that you reboot the system. Select **NO** again.
17. If there are other QLogic HBAs installed, repeat steps 5 through 16 until all adapters have been installed.
18. Reboot the host.

Updating the HBA Driver in a Windows 2000 or Windows 2003 Host

On Windows 2000 and Windows 2003 systems where the QLogic HBA has been detected automatically or a driver is already installed, it might be necessary to update the current driver to the latest EMC-qualified driver, as described in this section.

The following procedure assumes that you have already copied the latest driver from the QLogic CD-ROM or downloaded it from the QLogic website and put it onto a diskette.

Refer to the release notes provided with the driver for information that might be unique to new driver revisions.

To install the driver into a Windows 2000 or Windows 2003 host:

1. Boot the host (if necessary) with Windows 2000 or Windows 2003.
2. From the Windows taskbar, click **Start, Programs, Administrative Tools, Computer Management**.
3. In the left pane of the Computer Management window, click the **Device Manager** icon.
4. Double-click the **SCSI & RAID Controllers** icon.
5. Under **SCSI & RAID Controllers**, double-click the adapter you wish to upgrade.
6. In the next window, click the **Driver** tab; then click **Update Driver**.
7. Follow the update wizard until you are given the choice to **Display a list of the unknown drivers for this device so that I can choose a specific driver**.

Click the button next to this choice; then click **Next**.

8. In the Select a Driver window, click **Have Disk**.
9. Enter the path to the diskette containing the driver (**A:**, for example), or use the browse function to locate the driver; then click **OK**.
10. Select the driver that is discovered and click **Next**.
11. In the next window, click **Next**.

12. If prompted, click **Yes** to continue the installation.
 13. Click **Finish** to complete the installation.
 14. If the system requests that you reboot the system and you have other adapters to update, select **NO**; then click **Close**.
 15. If the system again requests that you reboot the system and you have other adapters to update, select **NO**; then click **Close**.
 16. If you have other adapters to update, select the next adapter under **SCSI & RAID Controllers** and repeat steps 6 through 15.
- When all adapters have had their drivers updated, select **Yes** to the `reboot` prompt.

Upgrading to Windows 2003 from Windows 2000 or Windows NT 4.0

Note the following if upgrading to Windows 2003:

- ◆ Upgrading from Windows NT 4.0 — The Windows NT4 drivers will not be preserved while upgrading to Windows 2003. You should obtain the correct Windows 2003 drivers (refer to *Downloading QLogic Drivers and Firmware* on page 2-2) and reinstall the drivers after the upgrade is complete.
- ◆ Upgrading from Windows 2000 — The Windows 2000 drivers may be preserved while upgrading to Windows 2003. These SCSIPort drivers (including the native Windows 2003 SCSIPort drivers) are not supported by EMC for Windows 2003. You should obtain the correct Windows 2003 drivers (refer to *Downloading QLogic Drivers and Firmware* on page 2-2) and reinstall the drivers after the upgrade is complete.
- ◆ Currently, to upgrade from Windows NT or Windows 2000 to Windows 2003, you must first uninstall PowerPath. After upgrading the host, you can reinstall an approved Windows 2003 version. Please refer to the EMC PowerPath documentation for further details.

You may wish to disconnect your storage during the Windows upgrade, and reconnect it after the approved Windows 2003 drivers have been installed.

Replacing an HBA

Procedure for Replacing a QLogic HBA in Stratus ftServers without Rebooting

EMC CLARiiON Storage arrays

Use of this procedure requires NAVICLI installed on the host system.

1. Remove the IO slice that contains the defective QLogic HBA.
2. Replace the defective HBA with a new HBA of same Stratus part number (that is, U525 or U526). The HBA should be inserted into the same PCI slot from which the defective HBA was removed. (Inserting the replacement HBA into another PCI slot requires a driver to be loaded for the HBA)
3. Re-insert IO slice with the new HBA, and re-connect all cables.
4. Power up the ftServer, and let the IO Slice come on-line and duplex, as shown in the Stratus ftServer Management tool.
5. Change the FC switch zoning to add the WWN of the replaced HBA to the appropriate zones.
6. Restart the Navisphere Agent using the **Service Control Manager** applet.
7. In the CLARiiON Navisphere Manager, use connectivity status to verify the new HBA is present and logged in. Alternately, use the port 'list' command in navicli.
8. Using navicli, connect the HBA to the storage group with the following command:

```
navicli -h <Clariion IP Addr> storagegroup -connecthost  
-host <host-name> -gname <Storage-group-name>
```

This command will give the user the following prompt:

```
Connect host <host-name>to storage group  
<Storage-group-name> (y/n)?
```

Respond with y.

9. Scan for hardware changes from the Windows device manager.

10. Execute the following commands from a command window:

```
powermt restore
powermt display
```

At this point, two HBA's should be present in the display and the FC HBA's should be duplexed in the ftSMC. It may be necessary to repeat steps 9 and 10.

EMC Symmetrix Arrays with Device Masking Enabled¹

Use of this procedure requires SYMCLI installed on the host system. Alternatively, EMC ControlCenter can be used to perform the HBA replacement.

1. Using SYMCLI, run **symmask list logins** to view the old WWN/iSCSI HBAs.
2. Remove all cables to the IO slice with the defective HBA, and remove the IO slice.
3. Replace the defective QLogic HBA with the new HBA of same Stratus part number (that is, U525 or U526). The HBA should be inserted into same PCI slot from which the defective HBA was removed. (Inserting the replacement HBA into another PCI slot requires a driver to be loaded for the HBA)
4. Re-insert the IO slice with the new HBA, and re-connect all cables.
5. Let the IO Slice come on-line and duplex, as shown in the Stratus ftServer Management tool.
6. Change the FC switch zoning to add the WWN of the replaced HBA to the appropriate zones.
7. Run **symmask list hba** or **discover** to view the new initiator (for example, WWN).
8. Run **symmask replace** to substitute a new WWN for all occurrences in the database of the old WWN.
9. Run **symmask discover** to establish the new names in the history table, or run **symmask rename** to assign a WWN to the new HBA in both the database and the history table.

1. Symmetrix Arrays without device masking enabled do not require this procedure; Symmetrix Arrays with device masking enabled only require replacing the HBA WWN used in switch zoning.

10. Run **symmask refresh** to update the director profile tables (in cache) from the database.
11. Scan for hardware changes from the Windows device manager.
12. Execute the following commands from a command window:

```
powermt restore  
powermt display
```

At this point, two HBA's should be present in the display and the FC HBA's should be duplexed in the ftSMC. It may be necessary to repeat steps 9 and 10.

Configuring an EMC Boot Device

Windows hosts have been qualified for booting from EMC storage array devices interfaced through Fibre Channel as described in the *EMC Support Matrix*. This chapter describes the process to configure a storage array device as a boot device.

- ◆ Introduction 3-2
- ◆ Configuring a Symmetrix Boot Device 3-5
- ◆ Configuring a CLARiiON Boot Device..... 3-14
- ◆ Boot Time and LUN Availability 3-35
- ◆ Replacing a Boot HBA 3-36
- ◆ How a Server Responds to Failure in the Boot LUN Path 3-37
- ◆ Known Issues..... 3-38

Introduction

Windows hosts have been qualified for booting from EMC array devices interfaced through Fibre Channel as described under *Boot Device Support* in the *EMC Support Matrix*.

Boot-from-SAN Configuration Restrictions

Refer to the *EMC Support Matrix* for any specific boot-from-SAN restrictions. This guide no longer contains restriction information, and the information in the *EMC Support Matrix* supersedes any restriction references found in previous HBA Installation guides.

Risks of Booting from the Storage Array

EMC recommends that you do not boot a Windows host from the storage array. However, if it is necessary to use the storage array as a boot disk, EMC recommends shutting down the host server during any maintenance procedures that could make the boot disk unavailable to the host.



CAUTION

Microsoft Windows NT 4.0 and Windows 2000 use virtual memory paging files that reside on the boot disk. If the paging file becomes unavailable to the memory management system when it is needed, the operating system will crash with a blue screen.

Any of these events could crash a system booting from the storage array:

- ◆ Lost connection to array (pulled or damaged cable connection)
- ◆ Array service/upgrade procedures, such as on-line microcode upgrades and/or configuration changes
- ◆ Array failures, including failed lasers on Fibre Channel ports
- ◆ Array power failure
- ◆ Storage Area Network failures, such as Fibre Channel switches, switch components, or switch power failures

- ◆ Storage Area Network service/upgrade procedures, such as firmware upgrades or hardware replacements

EMC recommends moving the Windows virtual memory paging file to a local disk when booting from the storage array. Consult your Windows manual for instructions on how to move the paging file.

How to Determine I/O Latency and Load on the Boot LUN

The current restrictions for boot-from-array configurations listed in the *EMC Support Matrix* represent the maximum configuration that is allowed using typical configurations. There are cases where your applications, host, array, or SAN may already be utilized to a point when these maximum values may not be achieved. Under these conditions, you may wish to reduce the configuration from the maximums listed in the *EMC Support Matrix* for improved performance and functionality.

Here are some general measurements that can be used to determine if your environment may not support the maximum allowed boot-from-array configurations:

- ◆ Using the Windows Performance Monitor, capture and analyze the *Physical Disk* and *Paging File* counters for your boot LUN. (For Windows NT 4.0, you might have to enable disk performance counters manually; refer to Microsoft support for the description and use of the Windows Performance Monitor.) If response time (sec/operation), or disk queue depth seem to be increasing over time, you should review any additional loading that may be affecting the boot LUN performance (HBA/SAN saturation, failovers, ISL usage, and so forth).
- ◆ Use available Array Performance Management tools to determine that the array configuration, LUN configuration and access is configured optimally for each host.

Possible ways to reduce the load on the boot LUN include:

- ◆ Move application data away from the boot LUN.
- ◆ Reduce the number of LUNs bound to the same physical disks.
- ◆ Select an improved performance RAID type.
- ◆ Contact your EMC support representative for additional information.

Boot Crashdump Save to Disk Behavior

If your system is configured to write crashdumps after system failures, and the host is configured to boot from the array, you will be able to successfully save the crashdump only on the original available boot device path on which the system started. This is a Windows limitation, and installing PowerPath will not affect this behavior. At the time a system crash is to be written to disk, Windows has already saved the original boot path, and PowerPath cannot redirect the crashdump file (`MEMORY.DMP`) to an alternative available device. If you have a configuration for which you want to capture a crashdump, you should ensure that the original primary boot path is available at the time of the crash.

Boot-from-SAN with MSCS

The current installation, configuration and limitation information for boot-from-SAN with Microsoft Clustering (MSCS) configurations can be found in the latest *EMC Host Connectivity Guide for Windows*. Please also refer to the *EMC Support Matrix* for approved boot-from-SAN MSCS configurations.

Configuring a Symmetrix Boot Device

This section describes how to install the Windows NT or Windows 2000 operating system onto an EMC Symmetrix® storage system connected to an Intel-based x86 class server. You can then boot Windows from the storage system.

Configuring the Boot BIOS

The procedure below describes how to configure the boot BIOS. The procedure assumes that the boot BIOS has been installed to the adapters already.

1. Connect the EMC storage array boot port to the adapter in the lowest-numbered PCI slot in the server. For example, if you have three adapters in the system in slots 2, 4, and 5, connect the cable to the adapter in slot 2. Do not connect cables to the other adapters at this time.
2. Boot the server, and press CTRL-Q when you see the QLogic banner:

Different HBA models may display different banners. Be sure to select CTRL-Q for the HBA you wish to configure.

```
QLogic Corporation
QLA2300 PCI Fibre Channel ROM BIOS Version 1.17
Copyright © QLogic Corporation 1993-1999 All rights reserved
Press <CTRL - Q> for Fast!UTIL
www.qlogic.com
```

3. After `Fast!UTIL` loads, the display depends on whether there are multiple QLogic HBAs installed:
 - If there is only one QLogic HBA, the `Fast!UTIL Options` menu appears.
 - If there are multiple QLogic HBAs, a list of addresses occupied by those HBAs appears. Since the EMC storage array is attached to the lowest-numbered PCI slot, select the first adapter from the list; then press ENTER. The `Fast!UTIL Options` menu appears.
4. From the `FastUTIL Options` menu, select **Configuration Settings** and press ENTER.

5. From the **Configuration Settings** menu, select **Host Adapter Settings** and press ENTER.
6. From the **Host Adapter Settings** menu, select **Host Adapter BIOS** and press ENTER to enable it if it is not already enabled.

Refer to *EMC HBA Settings* on page 2-8 for a table of EMC-approved NVRAM settings.

7. Press ESC to exit the **Configuration Settings** menu.
8. From the **Configuration Settings** menu, select **Selectable Boot Settings** and press ENTER.
9. From the **Selectable Boot Settings** menu, select **Selectable Boot Device** and press ENTER to enable it if it is not already enabled.
10. Select **Current Boot Node Name** and press ENTER.

The adapter scans for attached storage devices, and displays them on the screen.

11. Choose the storage array port from which you wish to boot. Its entry will be similar to the following:

ID	VENDOR	PRODUCT	REV	NODE NAME	Port ID
12	EMC	SYMMETRIX	5566	50060482BFD06C02	0000E4

Select your boot device and press ENTER.

A list of LUNs will appear in a new window. Select the LUN from which you wish to boot and press ENTER.

12. Press ESC at the **Selectable Boot Settings** menu to return to the **Configuration Settings** menu.
13. Press ESC at the **Configuration Settings** menu to return to the **Fast!UTIL Options** menu.

Select **Save Changes** and press ENTER.

14. Press ESC to exit **Fast!UTIL**.
15. Reboot the host.

Installing the Windows OS onto the Boot Device

Follow the appropriate steps below to install the Windows operating system onto the EMC boot device.

Windows NT

Microsoft does not provide a driver for the QLogic controllers on the Windows NT installation CD-ROM. In order to properly install Windows NT on a the EMC storage array boot device connected to a QLogic controller, the Windows installation diskettes must be used with the CD-ROM.

1. Boot the server with Windows NT installation diskette 1. The server displays the following message, followed by a blank blue screen. Press F6 as soon as the blue screen appears:

```
Setup is inspecting your computer's hardware configuration ---
```

Pressing F6 tells the Windows installer that you want to load a third-party driver before proceeding with the installation.

2. Follow the prompts to insert the necessary diskettes until the setup stops to allow you to add additional devices.

A dialog message will tell you that the setup program cannot determine the type of one or more mass storage devices.

From this point, press S to specify additional devices. You will need to select **Other** and press ENTER.

3. Insert the QLogic driver disk into the diskette drive and press ENTER.
4. You are prompted to select one of four driver choices. Select **QLogic QLA2300 (or QLA2200) PCI Fibre Channel Adapter** and press ENTER.

The driver loads and you are brought back to the **Additional Devices** dialog.

5. You must now load the driver for your CD-ROM drive. The Windows NT installer assumes that you want to specify all storage drivers now. If the CD-ROM is not selected, installation will fail later in the process.

Press S to specify an additional device.

6. From the list, scroll up to select **IDE CD-ROM (ATAPI 1.2)/PCI IDE Controller** and press ENTER.

7. Some servers use SCSI CD-ROM drives. If your server has a SCSI CD-ROM, repeat steps 5 and 6 to select the driver for the SCSI controller. If your controller is not on the list, obtain the driver on diskette from the vendor.
8. If you want to specify drivers for other devices installed in your system, do so; otherwise press ENTER at the **Additional Devices** dialog to continue with Windows installation.
9. After completing Windows installation, reinstall the QLogic driver using the steps under *Installation Procedure for Windows NT Hosts* on page 2-15.

Windows 2000

For detailed installation instructions on the HP ProLiant BL20p G2 and BL40p, refer to *HP ProLiant BL p-Class server blades Booting Windows systems from 3rd party Storage Array Network (SAN), How To*, located here:

`ftp://ftp.compaq.com/pub/supportinformation/techpubs/other/5982-3248en_rev1_us.pdf`

After completing Windows installation, reinstall the QLogic driver using the steps under *Installation Procedure for Windows 2000 and Windows 2003 Hosts* on page 2-16.

Installing EFI boot code onto the HBA

To boot from a Symmetrix device via a QLogic fibre controller under the Extensible Firmware Interface (EFI) shell, QLogic EFI boot code must be loaded to the HBA. EFI boot code provides the ability to boot from an attached device over Fibre Channel.

Check the EMC Support Matrix for the minimum required EFI boot code revision.

The CD-ROM contains the latest EMC-approved EFI boot code at the time of this document's release. Update EFI boot code files, if available, can be found on the qLogic website <http://www.qlogic.com>.

NOTE: If your system does not have a floppy disk driver, a USB pen drive can be used to run utilities and store files for this procedure. Check with your server vendor to determine whether a USB pen drive is supported for your system.

If a system contains of mixture of detected and undetected adapters, any existing

EFI drivers loaded by EFI should be unloaded using the EFI Shell **drivers**, and **unload** commands. If you have not previously installed EFI boot code to your QLogic HBA, skip this section.

1. Type **drivers** at the EFI shell prompt to display the list of loaded EFI drivers. You will see an entry (or entries) similar to the following:

```
5D 0000011E B X X 1 HP 2 Gb Fibre Channel Driver      PciRom Seg=00000000
5D 00000140 D X X 1 - QLogic Fibre Channel Driver    PciRom Seg=00000000
```

2. The first column (in this example, 5D) is the driver handle for the HBA. To unload the EFI boot code driver, use the **unload** command:

```
unload 5D
```

3. After all instances of the QLogic EFI boot code driver are unloaded, proceed to the next section.

To flash the HBA with the latest EFI boot code, copy the files from the EFI boot code package to a floppy disk. If your system does not have a floppy drive, a USB pen drive can be used instead. If your system is already booted to the EFI shell, insert the floppy or USB pen drive and type **exit** to exit the EFI shell. From the boot options menu, select **EFI Shell [Built-in]** to go back into the EFI shell. This will cause the EFI shell to re-discover disk devices and will locate the floppy or pen drive.

When you enter the EFI shell, the device map should be displayed. If it does not display, type **map** at the `shell>` prompt to display the list of detected devices. Disk devices that are accessible by the EFI shell are listed as FS devices. Switch to the device containing the EFI boot code. This is accomplished by typing the name of the device and a colon. For example, if the EFI boot code is on `fs1`, type **fs1:** and press ENTER to switch to that device. If your HBA does not have EFI boot code already installed, you must use the `EFIUTIL.EFI` driver utility in order to flash the board. At the command prompt, type **EFIUTIL** and press ENTER. This will load the QLogic EFI utility and display a `efiutil>` prompt. The following commands assume that the EFI boot package files are all located in the same directory as the `EFIUTIL.EFI` program.

1. To load the EFI driver onto the HBA, type **ew** and press ENTER. The driver image binary filename, by default, is `q12312ef.bin`. The EFIUTIL program will prompt for the filename, and pressing ENTER selects the default. Confirm that the version being installed is correct by typing **y** and pressing ENTER. The driver will begin flashing to the HBA. The `efiutil>` prompt will reappear when the load is complete.
2. To load the HBA risc code onto the HBA, type **rw** and press ENTER. The firmware image binary filename, by default, is `q12312fw.bin`. The EFIUTIL program will prompt for the filename, but pressing ENTER will select the default. Confirm that the version being installed is correct by typing **y** and pressing ENTER. The firmware will begin flashing to the HBA. The `efituil>` prompt will reappear when the load is complete.
3. To load the EMC NVRAM settings to the HBA, type **nw** and press ENTER. The NVRAM data filename provided on the HBA kit is `NVRAM23.DAT`. The EFITUIL program will prompt for the filename. Type `NVRAM23.DAT` at the prompt and press ENTER. The EFITUIL program will load the NVRAM settings to the HBA and the `efituil>` prompt will reappear.
4. Type **quit** to exit the EFIUTIL program and return to the EFI shell.
5. Type **reset** at the EFI prompt to reboot the server.

Configuring QLogic EFI boot code to boot from an External Array

QLogic EFI boot code configuration is text-based. It involves running a command line utility to setup the HBA for boot. The following procedure should be conducted after you have done the following:

1. Write down the world wide name for the port that you will be booting from on the storage array. Consult your documentation or EMC customer service rep. to determine this number for your array.
2. Determine and note the LUN on the array that you will be booting from.

To configure the EFI boot code, you must start the EFI driver utility for the HBA. To do this, you must determine the driver handle and driver control number for the HBA you will be booting from:

1. Enter the EFI shell on the system

2. At the `shell>` prompt, type **drivers** and press ENTER. The list of currently loaded drivers will be displayed. The QLogic EFI driver should appear on a line that is similar to that shown below:

```
5D 0000011E B X X 1 HP 2 Gb Fibre Channel Driver PciRom Seg=00000000
5D 00000140 D X X 1 - QLogic Fibre Channel Driver PciRom Seg=00000000
```

3. The first two hex digits are the driver handle. To determine the control number, type **drvcfg <handle>** and press ENTER. You will see both the handle and control numbers displayed for that HBA:

```
Configurable Components
  Drv[5D]Ctrl[60]Lang[eng]
```

4. To start the EFI command line utility, type **drvcfg -s <handle> <control>** and press ENTER. (for example, `drvcfg -s 5d 60`)
5. At the selection prompt, select menu choice **8 (info)** and press ENTER. This will display the HBA information, which includes the world wide number of the HBA. Write the WWN down to aid in fabric zoning.
6. At the selection prompt, select menu choice **3 (edit_database)** and press ENTER.
7. At the Entry in WWN database to edit prompt, type **0**.
8. At the Entry 0 Port WWN prompt, enter the 16 digit WWN of your storage array boot port recorded earlier. Do not enter the HBA WWN that was noted in step 5.
9. At the Node WWN prompt, retype the storage array WWN again.
10. At the LUN (hex) prompt, type the LUN number that you will be booting from.
11. Once entered, the Entry in WWN database to edit prompt will re-appear. This gives you the chance to configure a secondary boot LUN. Repeat steps 7 through 10 for up to 4 alternate boot LUNs. Simply type in the database number (1-4) to configure them. If you are finished with configuring boot LUNs, press ENTER at this prompt to return to the `eficfg>` prompt.
12. At this point, edit the HBA settings to make sure the topology and other parameters are correct for boot. Select menu choice **1 (edit_adapter_settings)** at the selection prompt and enter values for the following parameters:
 1. Enable Hard Loop Id? = Y (Note: Only necessary for direct-connect configurations)

2. Hard Loop Id (hex) = 255 (Note: Only direct-connect configurations also.)
3. Reset Delay (dec) = 5 (default)
4. Enable FC Tape = Y (default)
5. Frame Size = 2048 (default)
6. Select the topology for your configuration. In most cases, the default setting will work for all configurations.
7. Data Rate = 2 (default)

Type 0 at the selection prompt to return to the main menu.

13. Next, we will ensure the HBA advanced settings are correct for boot. Select menu choice **2 (edit_advanced_settings)** at the selection prompt and enter values for the following parameters:

1. Operation Mode = 0 (default)
2. Interrupt Delay Timer (dec) = 0 (default)
3. Execution Throttle (dec) = 256
4. Login Retry Count (dec) = 8 (default)
5. Port Down Retry Count (dec) = 45
6. Link Down Timeout (dec) = 0
7. Luns Per Target (dec) = 256
8. Enable Extended Logging = N (default)
9. Enable LIP Reset = N (default)
10. Enable LIP full login = Y (default)
11. Enable target reset = Y (default)

Type 0 at the selection prompt to return to the main menu.

14. After all the settings are correct, select menu choice **11 (write)** at the selection prompt to save them to the HBA.
15. After saving the changes, select menu choice **12 (quit)** to exit the EFI command line utility.
16. Reboot the server (**reset** at the Shell> prompt) to cause changes to take effect.

At this point, the HBA is ready to boot from the assigned LUN. Your fabric may not be configured with the correct zoning information to allow the HBA to see the storage array. After the server boots up, you will be able to view the WWN of the HBA in the fabric utility. From

there, you can configure your zone(s) on the fabric to allow the HBA to connect to the array properly.

Procedure to Install Windows Server 2003 on a Fibre Channel Disk (Only for system with floppy disk drive).

1. Boot with Windows Server 2003 Setup Media (See Microsoft Documentation for details).
2. Monitor the white bar on the bottom of the screen.
3. Press F6 within 5 seconds when the message `Press F6 if you need to install a third party SCSI or RAID driver` is displayed.
4. When the message `Setup could not determine the type of one or more mass storage devices installed in your system, or you have chosen to manually specify an adapter.` is displayed, insert the QLogic driver diskette.
5. Follow the remaining instructions as displayed to complete the Windows Server 2003 installation.

Configuring a CLARiiON Boot Device

This section describes how to install a boot device onto an EMC CLARiiON® storage system connected to an Intel-based x86 class server. You can then boot Windows from the storage system.

This section assumes that EMC did *not* prepare the server or the storage system to boot Windows from the storage system.

SCSI hard disks are allowed in configurations that boot over Fibre Channel. However, the BIOS for a SCSI disk's SCSI adapters *must be* disabled. You should also disconnect any SCSI disks before installing Windows.

Procedure Flowchart

The installation procedure includes steps you must follow in a specific order. The following flowchart outlines the major steps.

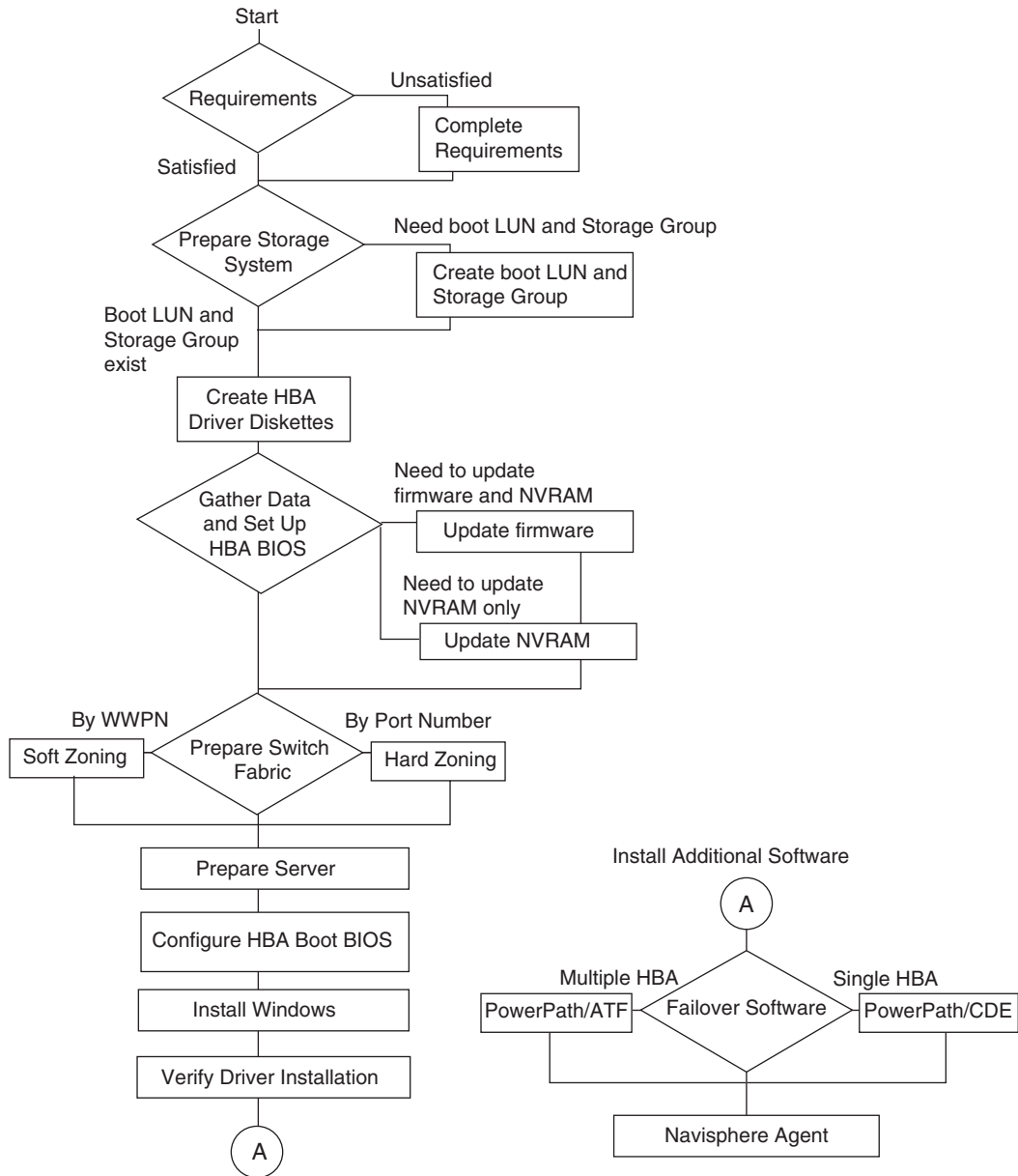

Requirements

Topologies, Configurations, and Revisions

This section lists supported configurations, hardware and software requirements, and related documentation.

Refer to the *EMC Support Matrix*.

Hardware and Software Requirements

Refer to the *EMC Support Matrix* for specific support information. Some general requirements are:

- ◆ Boot server with a CD-ROM and diskette drives, and support for the Windows version you will install. Refer to the *EMC Support Matrix* for supported servers.
- ◆ Latest HBA firmware and drivers for your operating system. Refer to *Downloading QLogic Drivers and Firmware* on page 2-2.
- ◆ One or more PCI Fibre Channel host bus adapters, installed in the lowest numbered PCI slot(s), which are the slots first scanned at startup, in the boot server.
- ◆ If installing in a fabric environment, Fibre Channel switch configured for IP, and with an available zone configuration utility (Telnet-based or Web-based).
- ◆ If required by the *EMC Support Matrix*, CLARiiON storage system with Access Logix™ and Access Control enabled (using EMC ControlCenter Navisphere Management software).

Until Windows is fully installed, you must connect *only* the storage system onto which the operating system will be loaded. Later, you can connect other storage systems.

- ◆ Cable connections as appropriate for server between server Fibre Channel HBA, switch (FC-SW only), and storage system SPs.
- ◆ Navisphere Management station with EMC ControlCenter Navisphere Management software or CLI. The station must be separate from the boot server but networked to the storage system (FC4700 and later array models) or connected to the storage system (models earlier than FC4700).
- ◆ The host system for Windows NT 4 must have less than 4.0 GB of physical RAM. (MSKB Q160392).

Media Requirements

Required media includes the following:

Refer to *Downloading QLogic Drivers and Firmware* on page 2-2.

- ◆ Latest EMC-approved Fibre Channel PCI HBA Driver Kit for Windows
- ◆ Latest EMC-approved Fibre Channel PCI HBA firmware
- ◆ MS-DOS boot diskette.

Preparing the Storage System

Boot device support requires a Navisphere Management station with Navisphere Manager or CLI. The station must be separate from the boot server but networked to the storage system (FC4700 and later model arrays) or connected to the storage system (models earlier than FC4700).

Before you can install Windows onto a storage system, the storage system must have at least one bound LUN in a Storage Group for the boot server. The LUN must be owned by the SP connected to the boot HBA.

For Windows NT 4.0, the host system boot LUN must be assigned Host LUN ID 0 by the EMC storage array. (MSKB Q218974)

During this installation procedure, you should have only one LUN in the boot Storage Group, so that you can easily identify the boot LUN. Later, you can add other LUNs to this Storage Group.

If you need to create a LUN, refer to the EMC ControlCenter Navisphere Management software documentation for your array type.

Setting Up the HBA BIOS

After the HBA is installed in the host and the EMC array is connected to the fabric (FC-SW) or directly connected to the HBA (FC-AL), you can configure an EMC-qualified QLogic HBA for boot support using `Fast!UTIL`, as described below:

1. Boot the server, and press `CTRL-Q` when you see the QLogic banner:

Different HBA models may display different banners. Be sure to select `CTRL-Q` for the HBA you wish to configure.

```
QLogic Corporation
QLA2300 PCI Fibre Channel ROM BIOS Version 1.17
Copyright © QLogic Corporation 1993-1999 All rights reserved
Press <CTRL - Q> for Fast!UTIL
www.qlogic.com
```

2. After `Fast!UTIL` loads, the display depends on whether there are multiple QLogic HBAs installed:
 - If there is only one QLogic HBA, the `Fast!UTIL Options` menu appears.
 - If there are multiple QLogic HBAs, a list of addresses occupies by those HBAs appears. Use the arrow keys to select the desired HBA; then press `ENTER`. The `Fast!UTIL Options` menu appears.
3. Select **Configuration Settings** from the menu.
4. Select **Host Adapter Settings**, and enable **Host Adapter BIOS**.

Refer to *EMC HBA Settings* on page 2-8 for a table of EMC-configured NVRAM settings.

5. Press `ESC` to return to the previous menu.
6. Select **Selectable Boot Settings**, and enable **Selectable Boot Device**.
7. For any entry that is not blank (all zeros), highlight the entry, and press `C` to clear any previous values.
8. When all parameters are set correctly, press `ESC` to return to the `Fast!UTIL Options` menu; then select **Save Changes** to save the changes you made to the current adapter.

9. Press ESC to exit the `Fast!UTIL Options` menu.
10. Reboot the host.

What Next?

The next step depends on the topology:

- ◆ FC-AL: Proceed to *Preparing the Server* on page 3-22.
- ◆ FC-SW: Proceed to *Preparing the Fabric* on page 3-19.

Preparing the Fabric

You can configure a switched fabric to support multiple hosts and multiple storage systems. For this setup, we will describe only the minimum configuration required for the boot LUN and server.

EMC recommends that you use switch zoning in all configurations to ensure consistency if your fabric grows.

The configuration below requires an existing knowledge of zoning and switch fabric concepts. The procedure explains the necessary steps to enable boot functionality for the storage system. This configuration does not cover the impact of zoning changes to other devices that will use the same connections. You should confirm your overall topology requirements and configuration before implementing any zoning changes.

Other devices on the fabric may introduce load and demand on the interlink components and storage system that can affect boot LUN performance and correct functionality.

The switch fabric must be configured initially so that the boot HBA is visible only to a single port on the storage system. That is, there must be only one zone containing the boot HBA and one SP port until installation is complete, even if you will install failover software later.

This can be accomplished in one of three ways (described following this list):

- ◆ Switch fabric soft zoning (by WWPN)
- ◆ Switch fabric hard zoning (by switch port)
- ◆ Physical connection of only one SP port to the fabric

Soft Zoning

These instructions let you configure the soft zoning as this setup requires. They are not a complete explanation of zoning. Refer to the documentation that is available for your switches for a complete guide.

1. Ensure that the server and storage system are cabled properly and powered on.

For the HBA's WWPN to appear in the Name Server database, the server must be in the boot BIOS menu. If the server is not in the boot BIOS menu:

- a. Reboot the server. When the QLogic BIOS banner (shown below) appears, press CTRL-Q:

Different HBA models may display different banners. Be sure to select CTRL-Q for the HBA you wish to configure.

```
QLogic Corporation
QLA2300 PCI Fibre Channel ROM BIOS Version 1.17
Copyright © Qlogic Corporation 1993-1999 All rights reserved
Press <CTRL - Q> for Fast!UTIL
www.qlogic.com
```

- b. After `Fast!UTIL` loads, the display depends on whether there are multiple QLogic HBAs installed:
 - If there is only one QLogic HBA, the `Fast!UTIL Options` menu appears.
 - If there are multiple QLogic HBAs, a list of addresses occupies by those HBAs appears. Use the arrow keys to select the desired HBA; then press ENTER. The `Fast!UTIL Options` menu appears.
 - c. Select **Configuration Settings** from the menu.
 - d. Select **Selectable Boot Settings** from the **Host Adapter Settings** menu; then select the first **Boot Port Name** entry.

The HBA will scan for available target ports. The HBA might not find any target ports, but this step allows the HBA to register with the switch database.
 - e. Leave the server, and continue to step 2.
2. Start a switch web-based or Telnet-based configuration session.

3. Create a **member** alias for the boot HBA WWPN. Make sure it is a **member** alias and that you use the **21... Port Name**, not the **20... Node Name**.
4. Create a **member** alias for one storage system SP port that you connected earlier and to which you bound the boot LUN. You can choose either Port 0 or Port 1 of the SP if both ports are connected to the switch. EMC recommends using Port 0 for consistency.
5. Create a zone and include the HBA alias and SP port alias created in steps 3 and 4.
6. Create a new zone configuration or select an existing zone configuration, and add the zone created in step 5.
7. Enable the zone configuration chosen in the previous step, and click **Apply**.
8. Ensure that any ports, aliases or zones composed of the HBA connection referenced above do not appear in any other zones or configurations that are enabled.

Important: If you have previously soft-zoned servers, they will not adhere to the new configuration unless they are restarted. Refer to the switch zoning manual for further information.

What Next?

Continue to *Preparing the Server* on page 3-22.

Hard Zoning

To use hard zoning:

1. Start a switch web-based or Telnet-based configuration session.
2. Create a zone and include the boot HBA port and one SP port. You can choose either Port 0 or Port 1 of the SP if both are connected to the switch. EMC recommends using Port 0 for consistency.
3. Create a new zone configuration or select an existing zone configuration, and add this zone.
4. Enable the zone configuration chosen in the previous step.
5. Ensure that any ports, aliases or zones composed of the HBA connection referenced above do not appear in any other zones or configurations that are enabled.

What Next?

Continue to *Preparing the Server* on page 3-22.

Physical Connection of Only One SP Port to the Fabric

If the SP that owns the boot LUN has only one port connected to the switch, and no other target devices are on the fabric, then zoning for the boot configuration is not necessary. You should make sure any existing zones still allow the HBA-to-SP connection.

Refer to the switch documentation for possible restrictions.

What Next?

Continue to *Preparing the Server*.

Preparing the Server

You must adhere to the configuration rules for your server when you install and set up the PCI cards. See the server installation and operation manual. All servers must meet the following requirements:

- ◆ The PCI Fibre Channel HBA must be the first HBA adapter scanned for boot.
- ◆ SCSI hard disks are allowed in configurations that boot from Fibre Channel. However, the BIOS for the disk's SCSI adapters *must be disabled*. You should also disconnect any SCSI disks before installing Windows. Reconnect or add SCSI hard disks when the installation is complete.
- ◆ You must have at least one EMC-qualified QLogic Fibre Channel HBA. Depending on your configuration, you can install additional Fibre Channel HBAs according to the topology rules in the *EMC Support Matrix*.

Perform the following steps:

1. Press ESC to exit the `Fast !UTIL` **Options** menu; then reboot the system.
You may receive a non-system disk error message; this is normal at this stage.
2. If any SCSI hard disk drives are connected, continue with step 3.

You might not be able to install Windows on the storage system if the server has a SCSI hard disk connected. The Windows Setup program may automatically assign the SCSI disk as drive C and install the operating system on that disk.

If no SCSI hard disk drives are connected to the server, go to step 4.

3. To disconnect all SCSI hard disk drives, unplug the power and SCSI bus cables connected to a SCSI adapter or controller. For details, see the installation and operation manual for your server.
4. To prepare your system to boot Windows over a Fibre Channel connection, you must do the following:

For detailed installation instructions on the HP ProLiant BL20p G2 and BL40p, refer to *HP ProLiant BL p-Class server blades Booting Windows systems from 3rd party Storage Array Network (SAN), How To*, located here:

ftp://ftp.compaq.com/pub/supportinformation/techpubs/other/5982-3248en_rev1_us.pdf

Following this installation proceed to *Verifying HBA Driver and Digital Signature Installation* on page 3-28. For other detailed instructions, refer to the manufacturer's documentation available for each adapter.

- For any server with IDE CD-ROM drives, you should *disable* BIOS on any of the server's integrated SCSI adapter(s) because SCSI BIOS is not required to boot from CD-ROM.
- Disable or remove any IDE HDD drives.
- For servers with SCSI CD-ROM drives, *enable* BIOS on the SCSI channel that includes the CD-ROM; *disable* BIOS on any other integrated SCSI channels. Remove any SCSI hard disks on the same bus as the CD-ROM drive.

If the CD-ROM is on a SCSI controller and the BIOS is disabled for that controller, then you will not be able to boot from the CD-ROM. To boot from CD-ROM in the future, you will need to re-enable the BIOS for the CD-ROM controller.

- Disable BIOS on any other HBA BIOS in your system other than the QLogic HBA(s) designated for booting. See the documentation that accompanied the HBA for instructions.

What Next?

Configure the HBA Boot BIOS as described in the next section.

Configuring the HBA Boot BIOS

Follow these steps to configure the storage system LUN for the HBA Boot BIOS:

1. Reboot the server.

When the QLogic BIOS banner (shown below) appears, press CTRL-Q.

Different HBA models may display different banners. Be sure to select CTRL-Q for the HBA you wish to configure.

```
QLogic Corporation
QLA2300 PCI Fibre Channel ROM BIOS Version 1.17
Copyright © QLogic Corporation 1993-1999 All rights reserved
Press <CTRL - Q> for Fast!UTIL
www.qlogic.com
```

2. After Fast!UTIL loads, the display depends on whether there are multiple QLogic HBAs installed:
 - If there is only one QLogic HBA, the Fast!UTIL **Options** menu appears.
 - If there are multiple QLogic HBAs, a list of addresses occupies by those HBAs appears. Use the arrow keys to select the desired HBA; then press ENTER. The Fast!UTIL **Options** menu appears.
3. Select **Configuration Settings** from the menu.
4. Select **Selectable Boot Settings** from the **Configuration Settings** menu.

Select the first **Boot Port Name** entry, and in the **Device** window scroll to select the CLARiON port WWN from which you want to boot.

Depending on the array model, the HBA may not yet detect any LUNs, or it may detect a *LUNZ* labeled disk. This is normal behavior.

Leave the server here so the HBA will remain active while you configure the storage array groups.

5. Using EMC ControlCenter Navisphere Management software, you must add the HBA to the storage group you created earlier. Depending on the array model, you may have to first manually register the HBA connection. If you will later install PowerPath or ATF, be sure to select the corresponding parameters during the registration procedure. Refer to your EMC ControlCenter Navisphere Management software, ATF, or PowerPath documentation for detailed instructions.
6. Press ESC until you exit the Fast!UTIL **Options** menu. You do not need to save any changes if prompted.
7. Reboot the server.

When the QLogic BIOS banner (shown in step 1) appears, press CTRL-Q.

Different HBA models may display different banners. Be sure to select CTRL-Q for the HBA you wish to configure.

8. After `Fast!UTIL` loads, the display depends on whether there are multiple QLogic HBAs installed:
 - If there is only one QLogic HBA, the `Fast!UTIL Options` menu appears.
 - If there are multiple QLogic HBAs, a list of addresses occupies by those HBAs appears. Use the arrow keys to select the desired HBA; then press ENTER. The `Fast!UTIL Options` menu appears.
9. Select **Configuration Settings** from the menu.
10. Select **Selectable Boot Settings** from the **Configuration Settings** menu.

Select the first **Boot Port Name** entry, and in the **Device** window select the CLARiON port WWN from which you want to boot.

After you select the WWN, if there is more than one LUN detected, select the boot LUN number from the next window.
11. When all parameters are set correctly, press ESC to return to the `Fast!UTIL Options` menu; then select **Save Changes** to save the changes you made to the current adapter.
12. Press ESC to exit the `Fast!UTIL Options` menu.
13. Reboot the server.

What Next?

Install Windows as described in the next section.

Installing Windows

You are ready to install the Windows operating system files. To install Windows, you need the following materials:

- ◆ Windows CD-ROM for the Windows version you wish to install.
- ◆ EMC-approved QLogic HBA driver diskette for Windows.

If you bound a new LUN to serve as your boot disk, ensure that the bind procedure is complete (EMC ControlCenter Navisphere Management software, LUN Properties tab **Percent Bound**).

1. Insert a bootable Windows CD-ROM in the drive and reboot the system.

If your system has a bootable disk already configured from a previous installation, the software will prompt you to press any key to boot from CD-ROM. If the bootable disk is not the storage array disk on which you want to install Windows, then you should disable that disk's SCSI BIOS as described under *Preparing the Server* on page 3-22.

2. Immediately after the Windows installation begins, press F6 when directed or when the blue screen appears following this banner:

```
Setup is inspecting your computer's hardware configuration ---
```

Pressing F6 tells the Windows installer that you want to load a third-party driver before proceeding with the installation.

If you do not press F6 in time to add the drivers, restart the server to try again.

3. When prompted for additional drivers, select **S**.
4. Insert the **EMC HBA Drivers** diskette for your OS. Then press ENTER to continue.
5. Select the appropriate QLogic boot HBA from the next menu.

Depending on the version of Windows, you may receive an error message that the default driver is newer than the provided one. Ignore this message, and select F6 to continue and use the driver you have provided.

6. Press ENTER to continue.

Setup continues to load files. The **Welcome to Setup** dialog appears.

7. Press ENTER to begin the setup procedure.

If you are installing Windows on a newly created LUN, you may receive a message that your boot disk is new or erased. You can press C to continue.

The **Windows Licensing Agreement** appears.

8. Press PG DN to scroll through and read the license agreement; to accept it, press F8.

The **Windows Server Setup** dialog displays disk partition information (if your system already contains partitions), or lets you create a new hard disk partition.

The Windows 2000 boot LUN can be larger than 8 GB (Refer to Microsoft Knowledge Base article Q240672.) Windows NT 4.0 is bound by a Boot BIOS 8 GB limit. (Refer to Microsoft Knowledge Base article Q224526.)

9. If you are installing an operating system for the first time, highlight **Unpartitioned Space on the qL2xxx** adapter; then:

- press ENTER to use the entire disk as one partition, or
- press C to create a custom partition, and then specify the partition size.

If the new disk is displayed as **Unformatted** or **Damaged** you must delete the partition before continuing. To do this, press D, then follow the on-screen delete instructions. After you delete the partition, the space will then appear as **Unpartitioned Space** mentioned above.

If you are reinstalling Windows, the Setup software prompts you to overwrite or upgrade:

- To overwrite, press ESC and follow instructions.
- To upgrade, press ENTER.
- If you want to create a new hard disk partition, you must first delete the existing partition, and then create a new one. To do so, select the partition you want to delete, press D, and then follow the on-screen instructions to complete the deletion of the partition. Once the system deletes the partition, you can press C to create a new one.)

10. The setup software prompts you to specify the file system format for the partition.

Select **NTFS** file system format, which is suitable for most sites unless you have other specific requirements. Then press ENTER. (For background information on the choice of the NTFS file system, refer to Microsoft Knowledge Base Article 0184006.)

Setup now formats the partition, copies the Windows system files to the partition, and starts rebooting the server.

11. When prompted, remove the diskette and CD-ROM.

If your system prompts you to press any key to boot from CD-ROM, *do not* press a key; allow the system to boot from the HBA adapter.

After booting, the system continues installation, displays the Windows banner, and begins autodetection of mass-storage devices and adapters.

12. Follow the on-screen instructions to complete the installation.

When the **Completing the Windows Setup Wizard** dialog appears, click **Finish**.

13. If you plan to add SCSI disks in the future, you should disable the BIOS for the managing SCSI controller so that the system does not attempt to boot from those disks. For information, refer to *Preparing the Server* on page 3-22.
14. Install the latest EMC-approved Windows Service Pack as explained in the Microsoft documentation.

What Next?

Verify that the Fibre Channel HBA drivers and (Windows 2000 only) digital signatures are installed and started, as described in the next section.

Verifying HBA Driver and Digital Signature Installation

You should install the HBA driver again here to ensure that the EMC-required settings are implemented. From the desktop, perform the appropriate steps:

- ◆ Windows NT: Follow the procedure under *Installation Procedure for Windows NT Hosts* on page 2-15.
- ◆ Windows 2000: Follow the procedure under *Updating the HBA Driver in a Windows 2000 or Windows 2003 Host* on page 2-18.

If duplicate devices appear in the **Disk Drives** section or **Disk Administrator** display, you have made errors in the switch fabric zoning configuration. Refer to refer to *Preparing the Fabric* on page 3-19 for the correct configuration procedure.

If you do not have a driver for Windows 2000 that is digitally signed, check the EMC section of the QLogic website for an updated driver. (Refer to *Where to Find the Driver* on page 2-14.)

What Next?

From here:

- ◆ If you need to install multipath and failover software, refer to *Installing Multipath and Failover Software*.
- ◆ If you need to start the installation again, refer to *Starting a Fresh Installation*.
- ◆ Otherwise, installation and setup are complete.

Assigning a Permanent Boot Drive Letter for Windows NT

If you have installed failover software into a Windows NT 4.0 server, it is good practice to hard-code the boot volume letter so that it does not change when rebooting after a LUN trespass. This can be done by using the following procedure (from MSKB Q153619):

1. Reassign all drive letters (including C: and the CD-ROM drive) to higher available letters. (You must do this or C: will be taken once it becomes available. After reassigning C:, you should receive a message requiring you to reboot for the new assignment to take effect.
2. Reboot the server.

On system restart you may receive virtual memory errors; this is normal.

3. Rename all drives to their original letters.
4. Reboot and make an ERD of the new configuration.

Installing Multipath and Failover Software

Multipath and failover software on the host can transfer control of storage system LUNs on a hardware failure in a LUN path.

Important: If the Navisphere Host Agent is installed, you must remove it before installing multipath and failover software. (Refer to the documentation that came with your failover software.) Reinstall the host agent after installing the multipath and failover software.

Follow these steps to set up the multipath and failover software:

1. Install the software as described in the your EMC ControlCenter Navisphere Management software, ATF, or PowerPath documentation.

2. Create and enable a zone for each additional HBA and SP port that will be supported by the multipath and failover software.

Refer to *Known Issues* on page 3-38 for any additional information.

Installing Additional Navisphere Host Agent Software

The EMC ControlCenter Navisphere Host Agent should be used to automatically register host connections with the array. PowerPath and ATF require different registration types and the Navisphere Host Agent is the preferred method over manual registrations.

You should install the Navisphere Host Agent software to ensure the HBA connections are all registered correctly. For instructions on how to perform this operation refer to the EMC ControlCenter Navisphere Host Agent software documentation for your array type.

After the host agent has started and registered the new HBA paths, you should refresh the host connections in the storage group to ensure all available paths are assigned. To do this, you have two options, depending on whether you want to disrupt the connectivity of the host:

- ◆ Without disrupting Host Connectivity (more complex procedure using Navisphere CLI):

Note: You must have Navisphere CLI installed. Refer to product notes for complete usage instructions.

RR:1. Using a command prompt, browse to the Navisphere CLI directory (typically C:\Program Files\EMC\Navisphere CLI>

6. Enter command **navicli -h <sp_IP> storagegroup -connecthost -host <hostname> -gname <storagegroupname>**

where <sp_IP> is the IP address of either array SP; <hostname> is the hostname of the host connection to update; and <storagegroupname> is the name of the storage group of the host connection to update.

7. When prompted, verify the <hostname> and <storagegroupname> are correct as follows:

```
Connect host <hostname> to storage group
<storagegroupname> (y/n)?"
```

Enter **y** to proceed.

8. Perform a device rescan on your host, and verify the additional device paths are present.
- ◆ With brief disruption of Host Connectivity (simpler procedure using Navisphere GUI):
 - RR:1.Shut down the host.
 9. Remove the host from the storage group.
 10. Apply the change.
 11. Add the host back into the storage group.
 12. Restart the host.
 13. Check the array connectivity status to ensure all connections you require are active.

Configuring Additional Boot Port Name Entries in the Boot BIOS

To take advantage of the high-availability features of the HBA boot BIOS, you must configure additional **Boot Port Name** entries in the BIOS for any additional SP ports from which you want the BIOS to attempt to boot during system startup. Depending on the failover software installed, follow the appropriate steps:

1. Reboot the host

When the QLogic BIOS banner (shown below) appears, press CTRL-Q.

Different HBA models may display different banners. Be sure to select CTRL-Q for the HBA you wish to configure.

```
QLogic Corporation
QLA2300 PCI Fibre Channel ROM BIOS Version 1.17
Copyright © QLogic Corporation 1993-1999 All rights reserved
Press <CTRL - Q> for Fast!UTIL
www.qlogic.com
```

2. After Fast!UTIL loads, the display depends on whether there are multiple QLogic HBAs installed:
 - If there is only one QLogic HBA, the **Fast!UTIL Options** menu appears.

- If there are multiple QLogic HBAs, a list of addresses occupies by those HBAs appears. Use the arrow keys to select the desired HBA; then press ENTER. The **Fast!UTIL Options** menu appears.
3. Select **Configuration Settings** from the menu.
 4. Select **Selectable Boot Settings** from the **Configuration Settings** menu.

The first **Boot Port Name** entry should already be configured (as described under *Configuring the HBA Boot BIOS* on page 3-23).

If you want another SP port to be accessible as a potential boot path to the current owner SP, select the next **Boot Port Name** entry, and in the **Device** window select the CLARiiON port WWN from which you want to boot.

5. If you have other HBAs for which you want to assign **Boot Port Name** entries, you can press ESC to go back to the main menu, save changes, and select another HBA as shown in step 2. If the other HBA you wish to configure has its own CTRL-Q BIOS prompt, reboot the server and configure that HBA's **Boot Port Name** entries as you have done here.
6. Trespass the LUN and repeat steps 1 through 5 to configure any paths over which you want to be able to boot the LUN from the other SP.

To trespass the LUN, follow the instructions in the EMC ControlCenter Navisphere Management software documentation for your array type. The process depends on the failover software installed:

- With PowerPath configurations, this can usually be done from the EMC ControlCenter Navisphere Management software GUI by right-clicking the desired LUN and selecting **trespass**. Confirm in the LUN properties that the LUN has trespassed before you return to configure the remaining **Boot Port Name** entries.
- With ATF configurations:
 - With FC-series array core code 8.45.x, this can usually be done from the EMC ControlCenter Navisphere Management software GUI by right-clicking on the desired LUN and selecting **trespass**. Confirm in the LUN properties that the LUN has trespassed before you return to configure the remaining **Boot Port Name** entries.

- With FC-series array core code 8.44.x and earlier, you will use the `atf_trespass` command to trespass the boot LUN. To do this, follow the steps under *Trespassing the Boot LUN Using `atf_trespass`* on page 3-33.

Each HBA can support multiple entries; you should configure **Boot Port Name** entries connecting to multiple ports on both SPs for maximum redundancy in booting after a boot LUN trespass or other link failures. Refer to Table 3-1 on page 3-37 to determine your high-availability requirements.

7. When all parameters are set correctly and you have added **Boot Port Name** entries for all the SP ports from which you would like to attempt to boot, press ESC to return to the `Fast!UTIL Options` menu; then select **Save Changes** to save the changes you made to the current adapter.
8. Press ESC to exit the `Fast!UTIL Options` menu.
9. Reboot the server.

Trespassing the Boot LUN Using `atf_trespass`

Follow these steps to use the `atf_trespass` command to trespass the boot LUN:

1. Boot the host and log in to Windows.
2. Windows NT 4.0 will have the boot LUN configured for ID 0 as described under *Preparing the Storage System* on page 3-17.

For Windows 2000, follow these steps to determine the LUN ID of the boot LUN as seen by the host:

- a. From the Windows task bar, select **Start, Programs, Administrative Tools, Computer Management**.
- b. On the **Computer Management** window, click **Disk Management**.
- c. Locate the System disk in the list. This is typically Drive `c:\` and will be noted with **(System)**.
- d. Select the **Disk X** description area, and from the **Action** menu, select **Properties**.

A display appears with a line similar to the following:

```
Device Type: SCSI (Port: 3, Target ID: 1, LUN:0)
```

- e. Find this `Device Type` line and note the LUN value. In this example, the LUN value is `0`. This is the Host LUN ID you will need in the next step.
3. Open a command window and direct the multipath and failover software to trespass the LUN. If you are using ATF, open a command prompt and change to the multipath and failover software directory; then enter the `atf_trespass` command:
 - If the boot LUN is owned by SP A, enter commands in the following form to transfer it to SP B:

```
cd Program Files\emc\atf
atf_trespass atf_sp0 1:1:n
```

 where *n* is the Host LUN ID you discovered in step 2.
 - If the boot LUN is owned by SP B, enter commands in the following form to transfer it to SP A:

```
cd Program Files\emc\atf
atf_trespass atf_sp0 0:1:n
```

These commands transfer the boot LUN to the other SP so you can configure it for failover in the HBA BIOS.
 4. Reboot the server.

Starting a Fresh Installation

To start a fresh installation:

- ◆ Using EMC ControlCenter Navisphere Management software, remove the old boot Storage Group.
- ◆ Using Manager, unbind the old boot LUN.
- ◆ Remove any old boot zoning from the previous installation.
- ◆ Repeat the installation instructions.

Boot Time and LUN Availability

Boot time is the amount of time a storage system requires to boot. This time is a function of the number and types of LUNs in the storage system, and is typically less than five minutes.

If you power up a server and storage system at the same time (cold start), the server's extended BIOS might scan the Fibre Channel bus

before the storage system is ready to respond. If this occurs, the server will not be able to find the boot LUN or Windows operating system. To avoid this problem, either power up the storage system and fabric before the server, or if the server is so equipped, set it to delay the scan until the storage system is ready.

Replacing a Boot HBA

If a boot HBA fails, you can replace it with a new one as described in this section.

EMC Symmetrix

Follow the procedure under *Configuring a Symmetrix Boot Device*.

EMC CLARiiON

- ◆ Shut down and power off the server.
- ◆ Replace the HBA in the identical location and reconnect cabling.
- ◆ (Fabric configuration only) Repeat the procedure under *Preparing the Fabric* on page 3-19, and replace the old HBA's WWPN with the new HBA's WWPN.
- ◆ Repeat the procedure under *Verifying HBA Driver and Digital Signature Installation* on page 3-28.

How a Server Responds to Failure in the Boot LUN Path

Failure in the path to a SAN-based boot LUN can halt Windows in a fatal error condition. Depending on the failure, Windows may be able to transfer control to another path and continue.

Table 3-1 shows server reactions to failures in different components.

Table 3-1 Server Response to Failure in the Boot LUN Path (Single Fault)

Configuration	Server State	HBA Failure	Switch Failure	Boot SP/Director Port Failure	Boot SP/Director Failure	Catastrophic Storage System Failure
2 or more HBAs, failover software	Windows running	Multipath	STOP error ^a	Multipath	Trespass ^b	STOP error
	Windows booting	Halt	Halt	Halt	Halt	Halt
	Power up	Multipath	No Boot ^a	Multipath	Manual	No Boot
1 HBA, failover software	Windows running	STOP error	STOP error	Trespass	Trespass ^b	STOP error
	Windows booting	Halt	Halt	Halt	Halt	Halt
	Power up	No boot	No boot	Manual	Manual	No boot
1 HBA, no failover software	Windows running	STOP error	STOP error	STOP error	STOP error	STOP error
	Windows booting	Halt	Halt	Halt	Halt	Halt
	Power up	No boot	No boot	No boot	No boot	No boot

a. Depending on the fabric configuration, if multiple switches are used, then this behavior would qualify under the Multipath category.

b. CLARiiON only.

Explanations of Entries

- ◆ **STOP Error** (fatal blue screen) — Indicates host failure and chance of data corruption.
- ◆ **No boot** — Cannot boot Windows.
- ◆ **Halt** — Windows cannot recover before system has completed startup. (You must reboot and follow the power-up scenario.)
- ◆ **Manual** — Manual intervention is required to continue. (Typically, initiate a LUN trespass using CLI or Manager. With Manager, enable LUN Auto-Assignment in LUN properties.)
- ◆ **Multipath** or **Trespass** — This automatic operation allows no disruption of service. (The delay caused by this operation may affect Windows stability.)

Known Issues

Be aware of these issues:

- ◆ QLogic BIOS 1.26 and later for QLA23xx and BIOS 1.79 and later for QLA22xx HBAs allow for multiple **Boot Port Name** entries to be configured for high-availability booting after path failures. Previous BIOS versions do not support this functionality, will boot only from a single storage array port, and cannot provide boot capability with path failures.
- ◆ NTOSKNL BSOD (blue screen) during a link down event can cause filesystem corruption to mounted filesystems.
- ◆ HBA boot BIOS does not support high availability while the OS is booting. It can handle path failures at boot initialization time, and after the OS has loaded. Path failures while the OS is loading will require the host to reboot before successfully completing the boot process. Refer to *How a Server Responds to Failure in the Boot LUN Path* on page 3-37 for additional information.
- ◆ Degraded response time as the I/O load approaches storage system capacity can make the OS appear hung or result in a NTOSKNL BSOD.
- ◆ Boot files, Windows system files, and swap space should all be on the boot LUN. With certain server models, you can use an internal disk for the page file for stability; however, this might not increase fault tolerance and might reduce system recovery options.
- ◆ Swap space must be available on %SYSTEMROOT% or core dump will fail.
- ◆ For Windows 2003 on 64-bit IA64-2 servers, the system no longer uses an x86-compatible BIOS; therefore, enabling boot-from-array support with the HBA requires a separate firmware EFI download.

Installing and Configuring the QLogic QLA4010 iSCSI HBA (TOE)

The QLA4010/4010C is an iSCSI HBA that provides PCI connectivity to SCSI using the iSCSI protocol. iSCSI enables IP-based SANs, which are similar to Fibre Channel SANs. The QLA4010/4010C HBA implements TCP/IP protocol on the HBA and off-loads the host of any I/O protocol processing. This type of adapter also is called a TCP/IP Offload Engine (TOE) adapter. Off-loading the host frees the system to perform other tasks and optimizes system performance.

- ◆ Installing the HBA Driver 4-2
- ◆ Windows 2003 STORPort Updates 4-2
- ◆ Updating the HBA Driver in a Windows 2000 or Windows 2003 Host 4-4
- ◆ Using the QLogic iSCSI SANSurfer Application to Configure iSCSI Devices 4-6
- ◆ Using the QLogic iSCSI SANSurfer Application to Configure iSCSI Devices 4-6
- ◆ Configuring iSNS settings for QLA4010..... 4-8
- ◆ Installing and Configuring the QLA4010 iSCSI HBA to boot from an EMC Storage Array 4-14

Installing the HBA Driver

To use EMC storage array disks with a Windows host, you need an EMC-qualified HBA driver. The HBA kit includes an EMC-approved driver, which must be installed and configured prior to partitioning the storage array disks. You should also check the QLogic website for the latest EMC-approved version. To ease installation of the driver, unzip the driver file onto a blank diskette or temporary folder on the hard disk.

Windows 2003 STORPort Updates

Installation Procedure for Windows 2000 and Windows 2003 Hosts

Currently, the shipping version of Windows 2003 requires post-RTM hotfixes to resolve some known issues. For all Windows 2003 STORPort installations, you should obtain the current Microsoft QFE hotfix listed in the EMC Support Matrix with the HBA driver revisions. Install this hotfix before installing the HBA driver.

To install the driver into a Windows 2000 or Windows 2003 host, follow these steps:

1. Boot the host with Windows 2000 or Windows 2003.
2. From the Windows taskbar, select **Start, Programs, Administrative Tools, Computer Management**.
3. In the left pane of the **Computer Management** dialog, click the **Device Manager** icon.
4. If Windows Plug-n-Play does not detect your QLA4010 HBA model, it will be listed as Unknown or as a Network Controller under the **Other Devices** icon in the right pane.

Windows 2000 configurations with Service Pack 4 or higher and Windows 2003 configurations may be able to detect QLA4010 HBAs. If this occurs, the HBA will already be listed under SCSI Devices; instead of proceeding with these installation steps, follow the instructions under Updating the HBA Driver in a Windows 2000 or Windows 2003 Host on page ?

5. Double-click the first instance of Unknown or Network Controller under **Other Devices**.

6. In the next dialog, click **ReInstall Driver**, and then, click **Next**.
7. Select **Display a list of the known drivers for this device** so that you can choose a specific driver, and then click **Next**.
8. Select **SCSI and RAID Controllers**, and then click **Next**.
9. Click **Have Disk**.
10. Enter the path to the diskette containing the driver (for example, A:\), then click **OK**.
11. Select the appropriate QLogic HBA from the list of drivers that appears; then click **Next**.
12. Click **Next** in the next dialog.
13. Click **YES** to continue the installation.
14. Click **Finish** to complete the driver installation.
15. The system requests that you reboot the system. Select **No** and click **Close**.
16. The system again requests that you reboot the system. Select **NO** again.
17. If other QLogic HBAs are installed, repeat steps 5 through 16 until all adapters are installed.
18. Reboot the host.

Updating the HBA Driver in a Windows 2000 or Windows 2003 Host

On Windows 2000 and Windows 2003 systems where the QLogic HBA is detected automatically or a driver already is installed, it might be necessary to update the current driver to the latest EMC-qualified driver as described in this section. The following procedure assumes that you have already copied the latest driver from the QLogic CD-ROM or downloaded it from the QLogic website and put it onto a diskette or temporary folder on the hard disk. Refer to the release notes provided with the driver for information that might be unique to new driver revisions.

To install the driver into a Windows 2000 or Windows 2003 host:

1. Boot the host (if necessary) with Windows 2000 or Windows 2003.
2. From the Windows taskbar, click **Start, Programs, Administrative Tools, Computer Management**.
3. In the left pane of the **Computer Management** dialog, click the Device Manager icon.
4. Double-click the SCSI & RAID Controllers icon.
5. Under **SCSI & RAID Controllers**, double-click the adapter you wish to upgrade.
6. In the next dialog, click the **Driver** tab; then click **Update Driver**.
7. Follow the update wizard until you are given the choice to Display a list of the unknown drivers for this device so that I can choose a specific driver. Click the button next to this choice; then click **Next**.
8. In the **Select a Driver** dialog, click **Have Disk**.
9. Enter the path to the diskette containing the driver (A:\, for example), or use the browse function to locate the driver; then click **OK**.
10. Select the driver that is discovered, and click **Next**.
11. In the next dialog, click **Next**.
12. If prompted, click **Yes** to continue the installation.
13. Click **Finish** to complete the installation.

14. If the system requests that you reboot the system and you have other adapters to update, select **NO**; then click **Close**.
15. If the system again requests that you reboot the system and you have other adapters to update, select **NO**; then click **Close**.
16. If you have other adapters to update, select the next adapter under **SCSI & RAID Controllers** and repeat steps 6 through 15. When all adapters have had their drivers updated, select **Yes** when prompted to reboot.

Using the QLogic iSCSI SANSurfer Application to Configure iSCSI Devices

QLogic provides a minimal version of their SANSurfer software that is used to configure settings for the QLA4010 iSCSI HBA. For configurations not using Microsoft's iSCSI Initiator, the SANSurfer iSCSI HBA Manager should be used to configure your iSCSI HBAs.

Install the SANSurfer iSCSI HBA Manager on your server using the self-extracting executable installation package (available in the EMC QLA4010 CD-ROM kit or from the qLogic website <http://www.qlogic.com>.) During installation, you may choose whether to install both the GUI and Agent, or just the GUI. If you are installing on the system that has the QLA4010 HBA(s) installed, install both the GUI and Agent.

After SANSurfer is installed, it can be started from the **Start** menu, or from the desktop icon if you choose to create one. Start the software, and you will reach the connection dialog shown below:

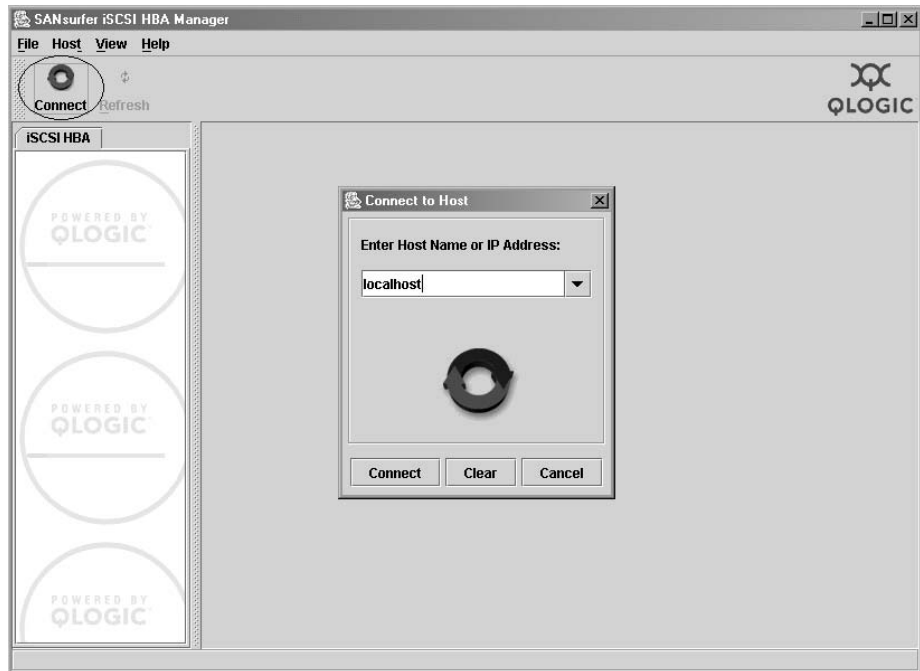

Click **Connect** in the upper left corner of the **SANsurfer iSCSI HBA Manager** window to get the **Connect to Host** dialog. You are asked

which host to connect to. Assuming you are running the software on the server with the HBA(s) installed, keep the default name of “local-host” as the host name, and click **Connect**.

On the GUI, the left pane displays discovered iSCSI HBAs. Click on the desired HBA in order to change its settings. The GUI defaults to the **HBA Options** dialog selected with the row of tabs at the top.

From the **HBA Options** dialog, you can set the iSCSI HBA parameters including IP address, subnet mask, and gateway. If an iSNS server is being used for your iSCSI configuration follow the procedure for setting up iSNS later in *Configuring iSNS settings for QLA4010* on page 4-8.

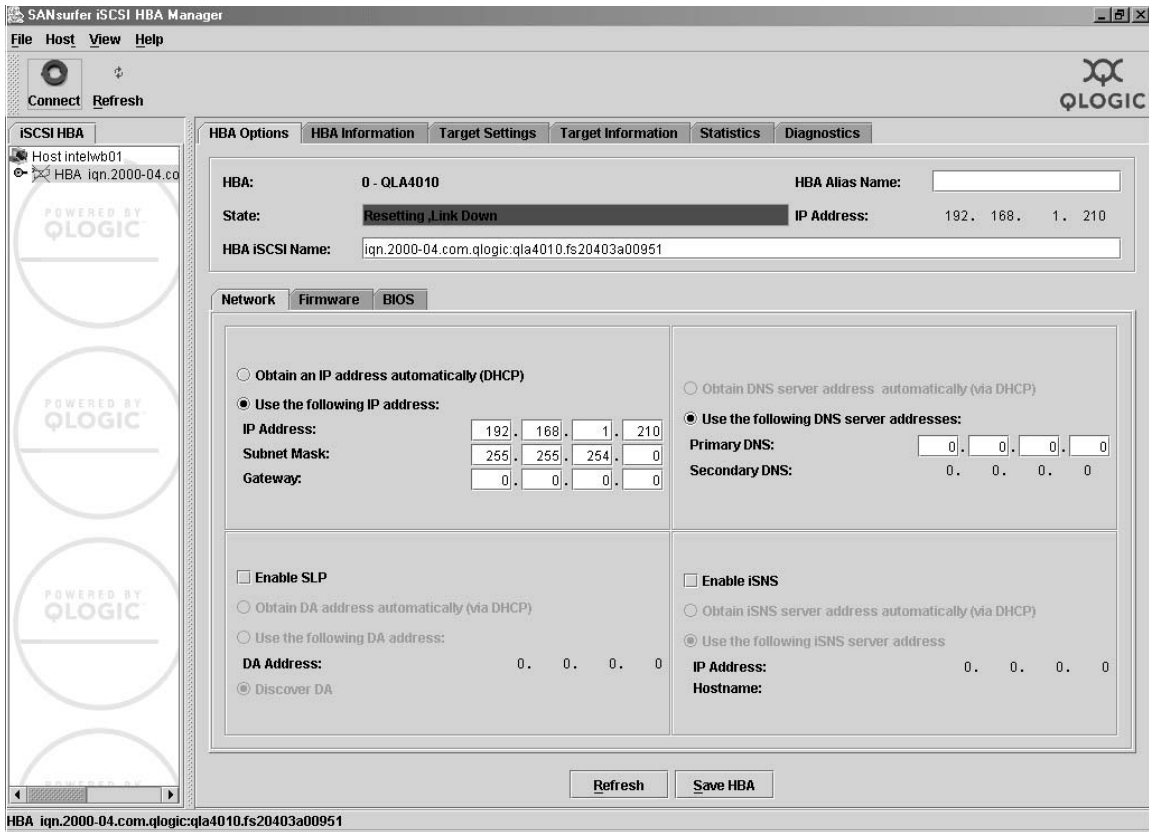

Configuring iSNS settings for QLA4010

For iSNS support, the QLA4010 must be running the correct driver (see the EMC Support Matrix for latest version.)

Targets must register with the iSNS server. To register, enable the iSNS server and enter the IP address using the SANsurfer GUI. Click **Save HBA** under the **Network** dialog box in the GUI. The target should be detected by SANsurfer in the **Target Settings** dialog. Click **SAVE Settings** to bind the targets.

If the targets are not detected, follow these steps:

1. Ping successfully to the iSNS server using **Diagnostics** tab from **SANsurfer iSCSI HBA Manager** window.
2. Go to iSNS server and iSNS server icon in the control panel or desktop
3. Open **Discovery Domain** and confirm that both the QLA4010 and target ports are registered with the domain.

To update firmware on your iSCSI HBA, click the **Firmware** tab on the **HBA Options** dialog.

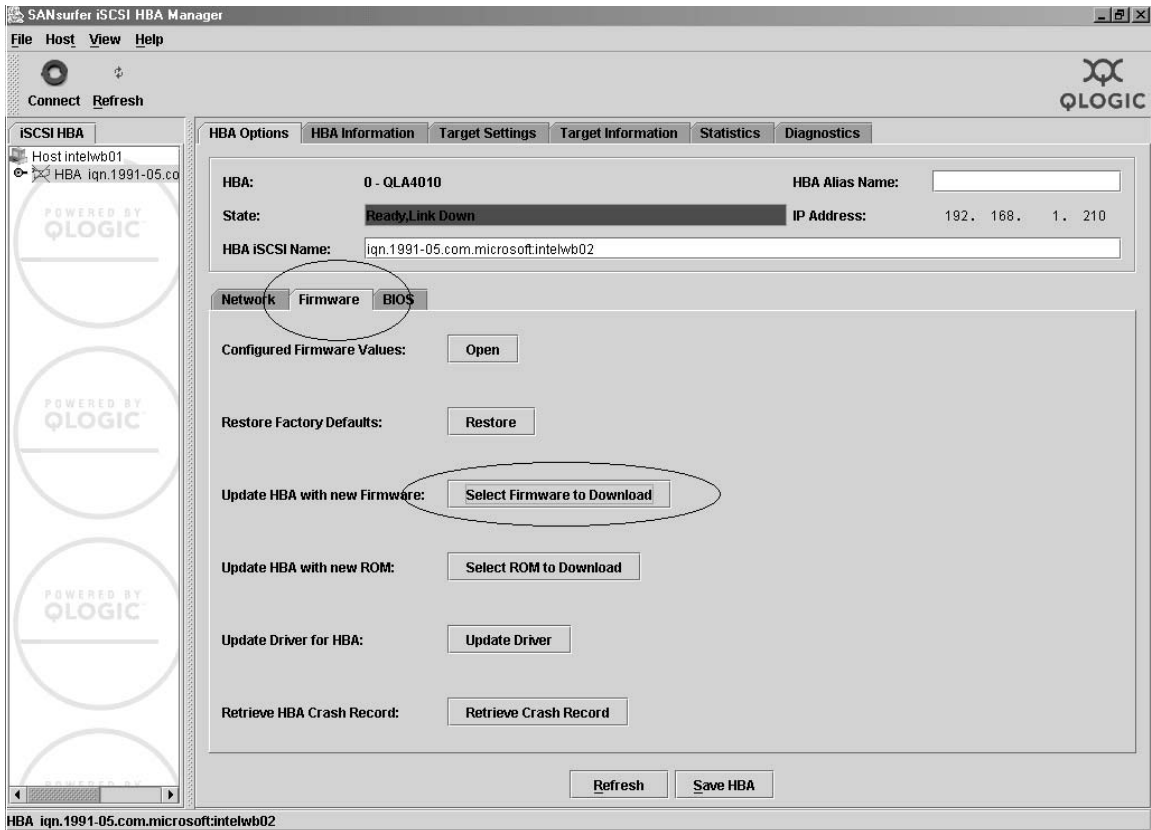

Click **Select Firmware to Download**. In the window that appears, type in the path to the firmware file that you wish to load to the HBA and click **Save**.



The firmware will be loaded to the specified HBA. Once loaded, SANsurfer will reset the HBA so that the new firmware will take effect.

Boot BIOS for the iSCSI HBA can be loaded in a similar fashion. From the **SANsurfer iSCSI HBA Manager**, **HBA Option** dialog, click the **BIOS** tab.

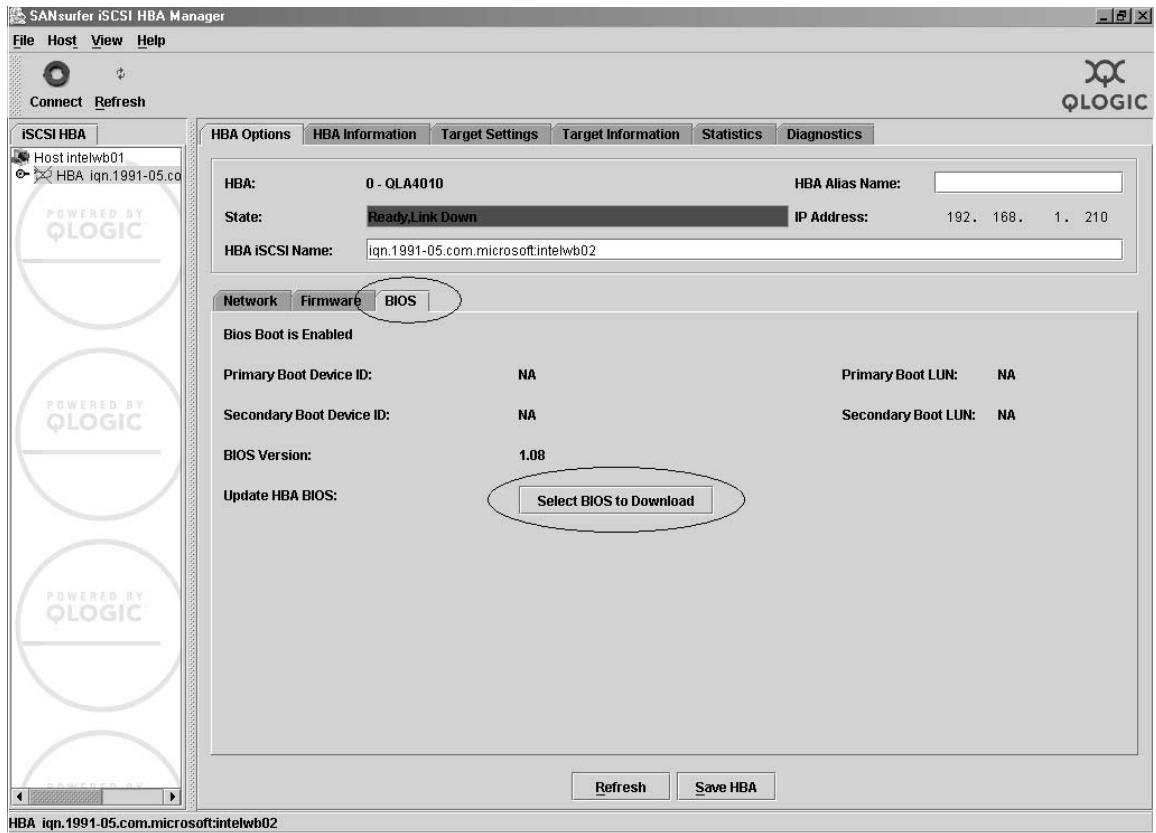

To configure your iSCSI targets, click the **Target Settings** tab from the **SANsurfer iSCSI HBA Manager** window.

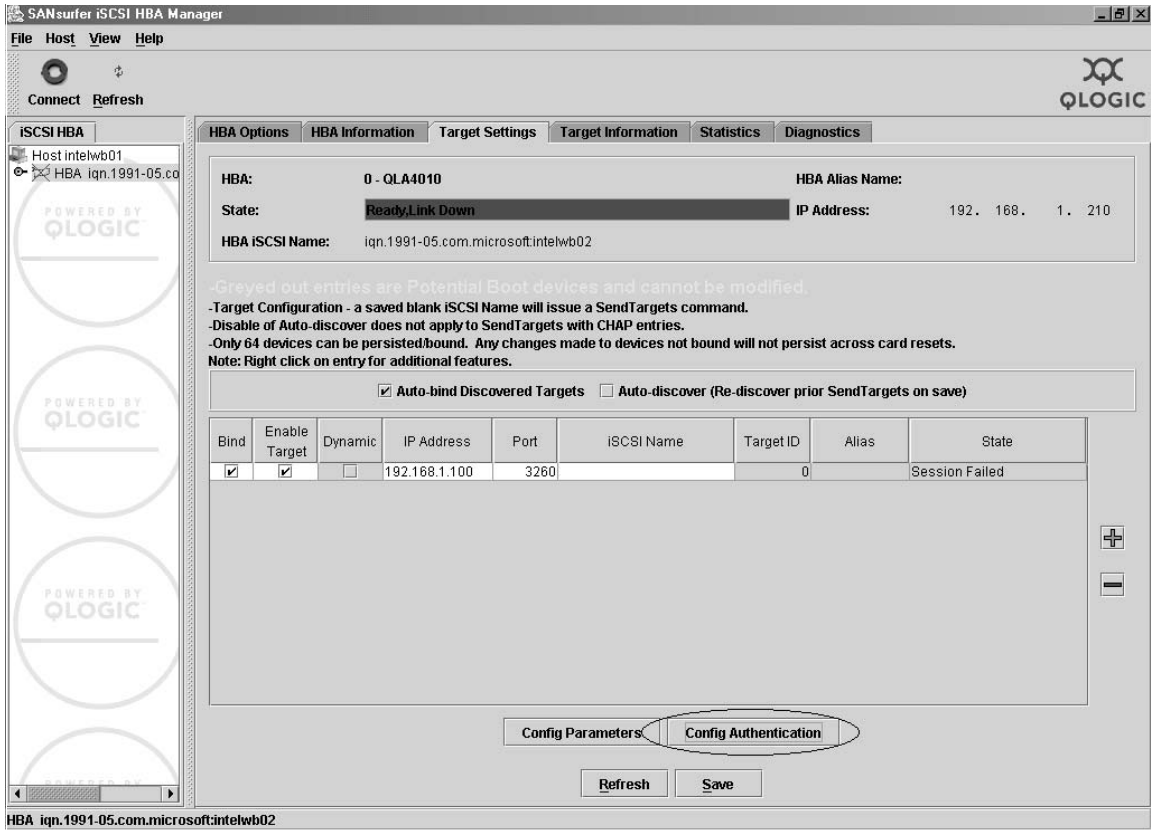

To add your target, click the green “plus sign” on the right side of the **Target Settings** dialog. You are prompted to enter the IP address of your target port

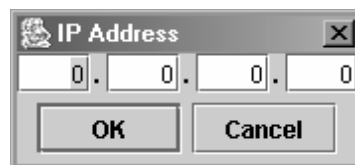

You may add as many targets as you need to here. If you need to enter CHAP security for any of the targets, click **Config Authentication** at the bottom of the dialog.

iqn.1991-05.com.microsoft:intelwb02 Authentication Configuration

CHAP **SRP**

Set Default Initiator Name and Secret

Initiator

Name:

Secret: Hex ASCII

Initiator Name and Secret

Enable	Target	Bidi	Initiator Name	Initiator Secret
<input checked="" type="checkbox"/>	192.168.1.100:3260 ...	<input type="checkbox"/>	CHAPName	CHAPSecret

Target Table

Target Name	Target Secret

You can set a default name and secret for all targets, or click the individual target and enter unique name and secret settings for that target. Note that initiator CHAP settings do not get masked and could be compromised if an unauthorized user accesses the SANsurfer workstation.

After CHAP settings are made, click **OK**. To save all target settings, click the Save button. You will be prompted for the SANsurfer secu-

rity password. The default password is “config” but may be changed.

When settings have been saved, SANsurfer will reset the HBA and if target information has been discovered properly, you will see active connections under the **Target Information** dialog. Also, you can see active targets under the HBA in the left pane as shown in this diagram.

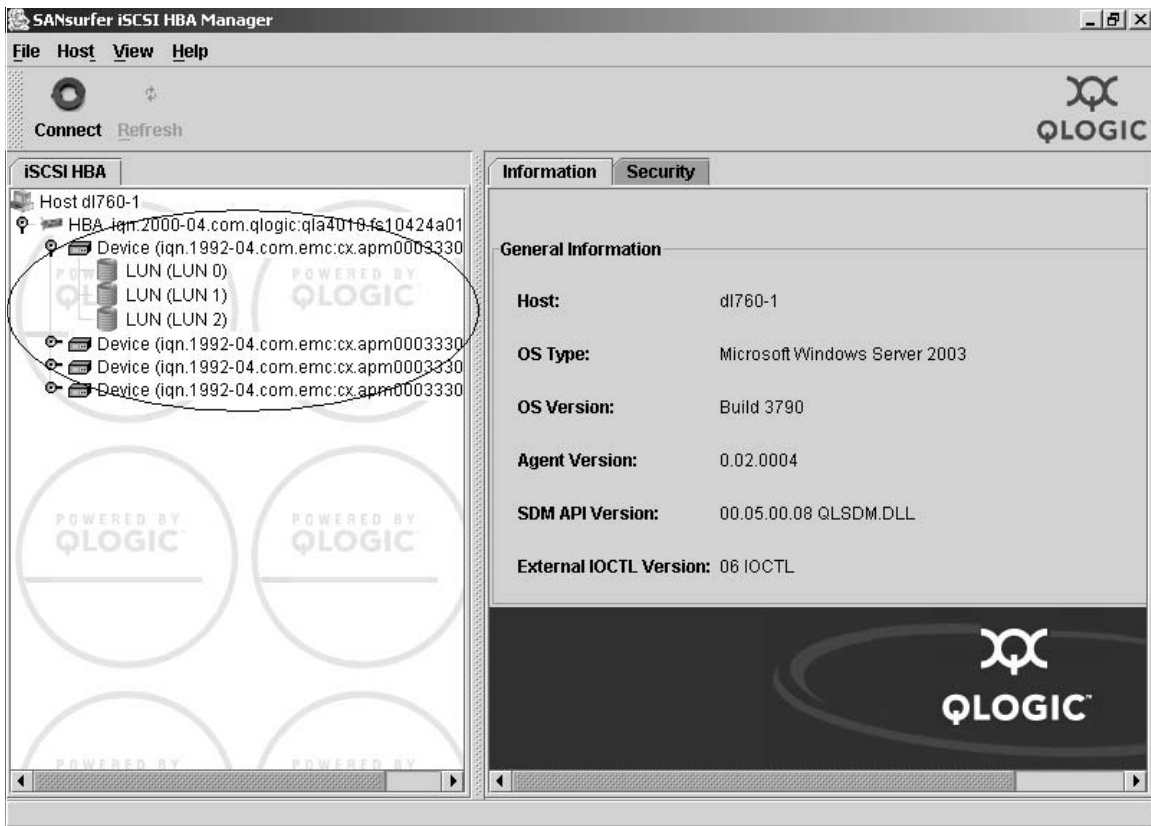

SANsurfer has other features that are useful in managing your iSCSI storage configuration. Please refer to QLogic’s SANsurfer documentation for more information about these extra features.

Installing and Configuring the QLA4010 iSCSI HBA to boot from an EMC Storage Array

The procedure below describes how to install and configure the boot BIOS.

Installing Boot BIOS on the QLA4010 iSCSI HBA from DOS

By default, the QLA4010 iSCSI HBA does not ship with Boot BIOS installed. Without Boot BIOS, the HBA cannot be configured to boot from an external storage array. Follow these steps to install Boot BIOS from DOS.

Note: Boot BIOS also can be installed using the SANSurfer utility.

1. Create a DOS-bootable floppy disk.
2. Copy the Boot BIOS .BIN file and QLogic flash utility onto the floppy. For the latest version of Boot BIOS refer to the EMC support matrix. The necessary files are: ql4010rm.bin, iFLASH.exe, and dos4gw.exe.
3. Boot the server with the floppy.
4. At the DOS prompt, type **iFLASH /fb** (this will program BIOS to all detected HBAs in the server.)
5. The iFLASH utility will display a message if the update was successful.

Setting Up the HBA BIOS

After the HBA is installed in the host and the EMC array is connected to iSCSI network, you can configure an EMC-qualified QLogic iSCSI HBA for boot support using Fast!UTIL, as described below:

1. Boot the server, and press CTRL-Q when you see the QLogic banner.

Different HBA models may display different banners. Be sure to select CTRL-Q for the HBA you wish to configure.

2. After Fast!UTIL loads, the display depends on whether there are multiple QLogic HBAs installed:
 - If there is only one QLogic HBA, the **Fast!UTIL Options** menu appears.
 - If there are multiple QLogic HBAs, a list of addresses occupies by those HBAs appears. Use the arrow keys to select the desired HBA; then press ENTER. The **Fast!UTIL Options** menu appears.
3. Select **Configuration Settings** from the menu.
4. Select **Host Adapter Settings**, and enable Host Adapter BIOS.
5. Set the LUNs per target to 256.
6. Set the Initiator IP address (EMC does not currently support DHCP for iSCSI HBAs.)
7. Set the subnet mask for the iSCSI HBA.
8. Set the network gateway IP address.
9. Select the Initiator iSCSI name, and press ENTER. This will display the complete IQN (iSCSI Qualified Name) for the iSCSI HBA. This is similar to the WWN for a fibre-channel HBA. Make a note of the IQN for LUN masking purposes if LUN masking is in use on your storage array.
10. If you are using CHAP security for your iSCSI network, enter the CHAP name and CHAP secret in the appropriate locations in the setting menu.
11. Press ESC to return to the previous menu.
12. Select **iSCSI Boot Settings**.
13. Select **iSCSI Boot**, and set it to enabled.
14. Select **Primary Boot Device Settings**, and press ENTER. Under the **Primary Boot Device Settings** dialog that appears, enter the security settings (if necessary), target (array port) IP address, and the target port (default of 3260 is the default port number for Symmetrix and CLARiiON iSCSI ports.) Boot LUN and iSCSI Name can be left blank.
15. Press ESC to return to the **iSCSI Boot Settings** dialog.
16. If you have a alternate boot port that you wish to use, select the Alternate Boot Settings, and repeat the steps in 14 above to set the second port.

17. Press ESC to return to the **Configuration Settings** dialog.
18. Press ESC again, and you will be prompted to save changes. Select **Save changes**, and press ENTER.
19. Select **Configuration Settings** again, and press ENTER.
20. Select **iSCSI Boot Settings**, and press ENTER.
21. To scan for your boot port, you can press enter on the primary boot device at the top of the **Boot Settings** dialog. The HBA will scan for targets and display them. If more than one target port is located, it will be displayed. It is helpful to know the IQN of your target port in order to select the correct target at this point. Select the target IQN of your target, and press ENTER.
22. The HBA will display the available LUNs under the selected target port. Select the LUN that you wish to boot from, and press ENTER. You may need to use the PAGE DOWN button to locate your boot LUN.
23. If you have an alternate boot target configured, repeat steps above to select the boot LUN for the alternate boot device.
24. When all boot LUNs have been selected, press ESC until you are prompted to save your changes. Once saved, the iSCSI HBA is ready to boot from the external array. Press ESC at the **Fast!UTIL Options** menu to reboot the host.

Installing the Windows OS onto the Boot Device

Follow the appropriate steps below to install the Windows operating copy the latest QLA4010 driver to a floppy disk for use during the installation procedure.

1. Boot the server with Windows 2000/2003 installation CD-ROM.

The server displays the following message, followed by a blank blue screen.

```
Setup is inspecting your computer's hardware configuration...
```

Press F6 as soon as the blue screen appears. Pressing F6 tells the Windows installer that you want to load a third-party driver before proceeding with the installation.

2. Setup will begin loading necessary drivers for installation. Eventually, a dialog message will tell you that the setup program cannot determine the type of one or more mass storage devices.

From this point, press S to specify additional devices. You will need to select **Other** and press ENTER.

3. Insert the diskette with the QLogic driver into the diskette drive, and press ENTER.
4. Select the driver by pressing ENTER. The driver loads and you are brought back to the **Additional Devices** dialog.
5. If you want to specify drivers for other devices installed in your system, do so; otherwise press ENTER at the **Additional Devices** dialog to continue with Windows installation.
6. Continue the installation procedure as though you were installing to an internal hard disk. Choose the correct boot disk for your iSCSI HBA from the list of discovered LUNs.

Windows 2000

For detailed installation instructions on the HP ProLiant BL20p G2 and BL40p, refer to *HP ProLiant BL p-Class server blades Booting Windows systems from 3rd party Storage Array Network (SAN), How To*, located here:

`ftp://ftp.compaq.com/pub/supportinformation/techpubs/other/5982-3248en_rev1_us.pdf`

After completing Windows installation, reinstall the QLogic driver using the steps under *Installation Procedure for Windows 2000 and Windows 2003 Hosts* on page 2-16.

NOTE: For Windows 2003 installations using the QLogic STORPort driver, it will be necessary to install the latest supported Microsoft STORPort hotfix (QFE). Refer to the EMC Support Matrix for the current hotfix version.

Third-Party Software

This appendix contains additional information about third-party software used with Windows hosts.

- ◆ QLogic SANSurfer SANBlade Manager A-2
- ◆ VERITAS Volume Manager 3.x for Windows 2000 A-4

QLogic SANSurfer SANBlade Manager

Stratus ftServers are not supported using the qLogic SANSurfer SANBlade Manager Software or Agents.

EMC has approved the use of a specialized version of the QLogic SANSurfer SANBlade Manager for use with attached EMC Symmetrix and CLARiiON storage arrays. Only the versions listed below should be used; these versions are posted in the EMC section on the QLogic website.

This Windows utility provides information on the installed QLogic HBAs, driver versions, mapped targets, statistics, and configuration settings. It also has a feature to update the HBA firmware/BIOS and NVRAM. (You should obtain the latest EMC-approved firmware/BIOS and NVRAM files from the QLogic website. Refer to *Downloading QLogic Drivers and Firmware* on page 2-2 for instructions.)

For information on the use and features of the QLogic SANSurfer SANBlade Manager utility, refer to the documentation posted with this utility.

SANSurfer Version History

SANSurfer versions include:

- ◆ 2.0.21 — Initial Release

The SANSurfer software is not multipath-aware, and as such may misreport HBA targets that are configured in multipath. This does not affect the use of the tool; however, it will accurately report targets only on ports that own an active LUN0.

- ◆ 2.0.25 — Added target persistent binding capability and display correction for LUNs on non-owning SP. (This functionality is supported by QLogic; all usage questions and support issues should be directed to QLogic.)

SANSurfer 2.0.25 cannot be used to upgrade to BIOS 1.4x. Until a later SANSurfer is available, you will need to use the procedure *Updating Using a DOS Boot Diskette* on page 2-11 to perform this upgrade.

This version of SANSurfer may display HBA options under different menu names than appear in the HBA CTRL-Q menu, as well as in previous SANSurfer versions. All user-configurable options are still accessible.

VERITAS Volume Manager 3.x for Windows 2000

Refer to the latest *EMC Support Matrix* to determine which VERITAS Volume Manager 3.x configurations are supported, and what service packs may be required.



CAUTION

Configuring large numbers of device paths with VERITAS Volume Manager can cause a Windows system to boot very slowly, and in some cases overrun the NTLDR boot-time registry size and halt. Systems that are configured with more than 512 device paths (total paths to all LUNs) should check with EMC Customer Service before installing VERITAS Volume Manager 3.x.

The C-bit is required on Symmetrix director ports connected to systems running VERITAS DMP. Users of EMC ControlCenter 5.1 and greater should consult their ControlCenter documentation for directions on making this change. Other users must contact their EMC representative to make this change.

VERITAS Volume Manager 3.0

If using PowerPath with VERITAS Volume Manager 3.0 with Service Pack 1, you must also make the following registry modifications before PowerPath devices will be available to the VERITAS Enterprise Manager:

Use **regedt32.exe** to set the registry as follows:

```
HKEY_LOCAL_MACHINE\SOFTWARE\VERITAS\VxSvc\CurrentVersion\VolumeManager
  value name = ShowGateKeeperDevices
  data type = REG_DWORD
  value = 0x1
HKEY_LOCAL_MACHINE\SOFTWARE\VERITAS\VxSvc\CurrentVersion\VolumeManager
  value name = ShowEmcHiddenDevices
  data type = REG_DWORD
  value = 0x1
```

After completing these changes, reboot the host system.

VERITAS Volume Manager 3.1 and VERITAS DMP

If using PowerPath with VERITAS Volume Manager 3.1, you also need VERITAS Volume Manager Service Pack 1.

EMC and VERITAS now provide a Dynamic Multipathing (DMP) Driver Update for VERITAS DMP to interface with CLARiON CX series arrays, providing DMP high-availability capability. Refer to the *EMC Support Matrix* for the minimum supported revisions of VxVM and DMP, as well as the CLARiON Dynamic Multipathing Driver update.

VERITAS Foundation Suite 4.1

Foundation suite encompasses VERITAS Volume Manager as well as other available volume management software utilities. Refer to the *EMC Support Matrix* for supported features of Foundation Suite.

For version 4.1, Volume Manager and DMP are supported with SCSI Port drivers only. VERITAS does not support STORPort drivers for Windows 2003 configurations.

VERITAS Foundation Suite 4.2

Foundation suite encompasses VERITAS Volume Manager as well as other available volume management software utilities. Refer to the *EMC Support Matrix* for supported features of Foundation Suite.

For version 4.2, Volume Manager and DMP are supported with both SCSI Port and STORPort drivers. For Windows 2003 STORPort driver configurations, the Microsoft STORPort hotfix is necessary. Refer to the *EMC Support Matrix* for current STORPort hotfix versions.

Foundation Suite encompasses VERITAS Volume Manager as well as other available volume management software utilities. Refer to the *EMC Support Matrix* for supported configurations and features of Foundation Suite. For version 4.2, Volume Manager and DMP are supported with both SCSI Port and STORPort drivers. For Windows 2003 STORPort driver configurations, the Microsoft STORPort hotfix is necessary. Refer to the *EMC Support Matrix* for current supported VERITAS versions, configurations and driver versions.

Troubleshooting

This appendix contains information on troubleshooting problems.

- ◆ Problems and Solutions..... B-2

Problems and Solutions

Problem 1

Error Message ID: 51 in event viewer when attempting to install multiple host access (for clustering) to the same EMC CLARiiON array storage group. The text of the message is:

```
An Error was detected on device \Device\Harddisk<x>\DR<x>
during a paging operation
```

Solution

Until host cluster software is installed, only a single host should access a storage group at a time. Refer to the *EMC Support Matrix* for supported host configurations.

Problem 2

EMC Primus case emc29097 — If using HBAs connected to both CLARiiON SPs, without PowerPath installed, duplicate LUNs will be visible in the Device Manager and Disk Manager. Only one instance of the LUN will be accessible, and all other matching mappings will be listed as Unknown, Unreadable and Unallocated.

Solution

This is normal behavior when multiple paths are available, PowerPath is not installed, and the initiator type is registered in PowerPath mode (array default depending on core code revision).

Problem 3

EMC Primus case emc69307 — When using QLogic HBAs in a Brocade fabric environment, after upgrading Brocade 3900-series switch firmware to 3.0.2m, the HBAs report repeated link errors, and intermittently lose fabric connectivity.

PowerPath may report paths lost and then found in quick succession, and repeated Windows 2000 event log error entries for Link Down/Link Up events similar to the following:

```
Event ID: 11
Source: ql2300
Description: The driver detected a controller error on \Device\Scsi\ql2300x.
Data (words): offset 34 = 80120000 [ErrorCode: Link down error]
```

```
Event ID: 11
Source: ql2300
Description: The driver detected a controller error on \Device\Scsi\ql2300x.
Data (words): offset 34 = 80110000 [ErrorCode: Link up]
```

Solution Upgrade to the latest HBA driver. This was corrected for Windows 2000 in 8.2.2.25 and later drivers. Windows 2003 driver 8.2.2.20 and later already contain this correction.

Problem 4

EMC Primus case emc69308 — Direct-connect to EMC CLARiiON CX200 reports incorrect queue full error messages. Even under light I/O, a host may log a message noting that disk has reached a queue-full state similar to the following in the Windows event viewer:

```
Event ID: 11
Source: ql2300
Description: The driver detected a controller error on \Device\Scsi\ql2300x.
Data (words): offset 34 = F003001C [ErrorCode: Target device queue full].
```

Solution Upgrade to the latest HBA driver. This was corrected in version 8.2.2.25 and later drivers.

Problem 5

Windows 2000 Hosts running less than SP4 could be susceptible to data loss during LUN expansion operations.

Solution This issue is corrected by Microsoft in SP4, or by applying hotfix 327020. Refer to EMC Solution IS emc73538 and Microsoft Knowledge Base article 327020 for more information.

Problem 6

For Windows 2003, the STORPort drivers 8.2.3.26 with Microsoft hotfix Q823728 and earlier do not yet fully support all Microsoft VSS functions.

Solution This was first corrected in Microsoft QFE hotfix Q837413 and to be used with minimum 8.2.3.27 driver. You should also use minimum Microsoft VSS QFE 833167.

Problem 7

When using SANSurfer 2.0.25 to update to BIOS 1.4x, you receive the message as follows:

```
Incorrect BIOS file selected.  
The selected BIOS file does not match the selected HBA type.  
Check your file and try again.
```

Solution SANSurfer 2.0.25 does not support flashing the 1.4x BIOS, you need to use the DOS FLASUTIL utility. This will be corrected in a future SANSurfer release.

Problem 8

IBM eServer BladeCenter HS20 Fibre Channel Expansion Card 48P7061 may not update all HBA BIOS in the system when using FLASUTIL.

Solution You may need to run FLASUTIL multiple times, and use /F to specify specific HBAs to update. Refer to the FLASUTIL instructions for further information.

A

adapter BIOS 2-2
adapter topology 2-13

B

binding, persistent 1-2, 1-3
BIOS
 adapter 2-2
 file 2-11
 updating 2-10
boot BIOS, configure 3-5
boot code, QLogic EFI 3-8
boot device, configuring
 CLARiiON 3-14
 overview 3-2
 Symmetrix 3-5
boot LUN 3-3
boot process, Windows 1-3
boot time and LUN availability 3-35
boot-from-SAN 3-4

C

CLARiiON storage 2-4
configurations, valid 3-16
crashdumps 3-4

D

data rate setting 2-12
data rate, HBA, setting manually 2-12
devices
 raw 1-2
 storage 1-3

discovery, disk 1-3
disk discovery 1-3
disk performance counters 3-3
disk signature 1-2
driver, HBA
 downloading 2-2
 installing
 in Windows 2000 host 2-16
 in Windows 2003 host 2-16
 in Windows NT host 2-15
 overview 2-14
 revision history 2-14
 updating
 in Windows 2000 host 2-18
 in Windows 2003 host 2-18
drives, physical 1-2

E

Extensible Firmware Interface (EFI) 3-8

F

failure in boot LUN path, server response to 3-37
Fast!UTIL 3-5
Fibre Channel HBA driver 2-14
Fibre-Down servers 2-10
file
 BIOS 2-11
 NVRAM 2-8, 2-11
firmware, HBA
 downloading 2-2
 updating 2-10
ftServers, Stratus 2-4, 2-9

H

hard zoning (switch) 3-21
HBA driver 2-14
HBA, boot, replacing 3-36
HBA, installing 2-3

I

issues with boot support 3-38

L

logical routing 1-2
LUN availability and boot time 3-35

N

NVRAM
file 2-8, 2-11
settings 2-8, 2-10

P

persistent binding 1-2, 1-3
physical drives 1-2

Q

QLogic EFI boot code 3-8

R

raw devices 1-2
routing, logical 1-2

S

SANSurfer SANBlade Manager A-2
server response to failure in boot LUN path 3-37
servers
Fibre-Down 2-10
Stratus ftServers 2-9
settings, NVRAM 2-8, 2-10
soft zoning (switch) 3-20
storage devices 1-3
STORPort installations, Windows 2003 2-15
Stratus ftServers 2-4, 2-9

T

topology requirements 3-16
topology, HBA, setting 2-13
troubleshooting B-1

V

VERITAS Volume Manager 3.0 A-4

W

Windows 2003 STORPort installations 2-15
Windows boot process 1-3
Windows drivers 2-2
Windows OS, installing onto a CLARiiON boot
device 3-25
Windows Performance Monitor 3-3

Z

zoning
hard 3-21
soft 3-20